

REACT 350[®] II

Product Description Assembly Manual

Part No. 618083B

Revision A July 2013



TRINITY
HIGHWAY PRODUCTS
ENERGY ABSORPTION SYSTEMS

REACT 350[®] II

Product Description Assembly Manual



2525 Stemmons Freeway
Dallas, Texas 75207



Important: These instructions are to be used only in conjunction with the assembly, maintenance, and repair of the REACT 350[®] II system. These instructions are for standard assembly specified by the appropriate highway authority only. In the event the specified system assembly, maintenance, or repair would require a deviation from standard assembly parameters, contact the appropriate highway authority engineer. This system has been accepted by the Federal Highway Administration for use on the national highway system under strict criteria utilized by that agency. Energy Absorption Systems representatives are available for consultation if required.

This Manual must be available to the worker overseeing and/or assembling the product at all times. For additional copies, contact Energy Absorption Systems at (888) 323-6374 or download from websites below.

The instructions contained in this Manual supersede all previous information and Manuals. All information, illustrations, and specifications in this Manual are based on the latest REACT 350[®] II system information available to Energy Absorption Systems at the time of printing. We reserve the right to make changes at any time. Please contact Energy Absorption Systems to confirm that you are referring to the most current instructions.

Table of Contents

Customer Service Contacts	3
Important Introductory Notes	3
Recommended Safety Rules for Assembly	4
Safety Symbols	5
Warnings and Cautions.....	5
Limitations and Warnings.....	6
System Overview	7
Assembly	8
Recommended Tools	8
Know Your REACT 350® II System.....	10
Backup Type	12
System Design.....	13
Self-Contained Backup.....	13
Concrete Backup	15
Foundation/Anchoring	17
Other Factors That May Affect Your Specification	20
Inspect Shipment	22
Assembly Procedures	22
Concrete Backups.....	26
MP-3® Polyester Anchoring System.....	34
Vertical Assemblies	34
Horizontal Assemblies	37
Maintenance and Repair.....	39
Life Expectancy	39
Parts Ordering Procedure	40
Visual Drive-By Inspection	40
Walk-Up Inspection	41
Post-Impact Instructions.....	42
REACT 350® II TL-3 w/Self-Contained Backup	43
REACT 350® II TL-3 w/Concrete Backup.....	44
REACT 350® II Transition Assembly, SC BU, UNI.....	45
REACT 350® II Transition Assembly, SC BU, N	46
REACT 350® II Transition Assembly, SC BU, N, w/Rub Rail.....	47
REACT 350® II Basetrack Assembly 36" Wide Units	50
REACT 350® II Concrete B-up Basetrack Assembly 36" Wide Units	52
REACT 350® II Transition Assembly for use w/Concrete Backup.....	55
REACT 350® II Cast-in-Place Concrete Slab w/Steel Backup 36"	56
REACT 350® Nose Cover Assembly TL-3	58
REACT 350® Chain/CYL Connector Assembly.....	59
REACT 350® Cable Assemblies	61
REACT 350® Reflector Assembly, White/Amber, Side	63
REACT 350® Misc. Hardware	64
REACT 350® 36" Debris Cover Assembly	65
REACT 350® Debris Cover Assembly.....	66
REACT 350® Drivable Pile Anchor Assembly	68
REACT 350® Sign Post Assembly Instructions.....	69

Customer Service Contacts

Energy Absorption Systems is committed to the highest level of customer service. Feedback regarding the REACT 350[®] II system, its assembly procedures, supporting documentation, and performance is always welcome. Additional information can be obtained by calling the telephone numbers below:

Energy Absorption Systems

Telephone:	(888) 323-6374 (USA Only) (214) 589-8140 (USA or International)
E-mail	customerservice@energyabsorption.com
Internet: Energy Absorption Systems Trinity Highway Products, LLC	http://www.energyabsorption.com/ http://www.highwayguardrail.com/

Important Introductory Notes

Proper assembly of the REACT 350[®] II system is essential to achieve performance of the system under appropriate federal and state criteria. These instructions should be read in their entirety and understood before assembling the REACT 350[®] II system. These instructions are to be used only in conjunction with the assembly of the REACT 350[®] II system and are for standard assemblies only as specified by the applicable highway authority. In the event your system assembly requires or involves deviation from standard parameters or, during the assembly process a question arises, please contact the appropriate highway authority that specified this system at this particular location for guidance. Energy Absorption Systems is available for consultation with that agency. These instructions are intended for an individual who is qualified to both read and accurately interpret them as written. They are intended for the individual who is experienced and skilled in the assembly of highway products which are specified and selected by the highway authority.

A set of product drawings will be supplied by Energy Absorption Systems. The drawings will be for each section of the assembly. These drawings should be reviewed and studied thoroughly by a qualified individual who is skilled in interpreting them before the start of any assembly.



Important: Read safety instructions thoroughly and follow the assembly directions and suggested safe practices before assembling, maintaining, or repairing the REACT 350[®] II system. Failure to follow this warning can result in serious injury or death to the worker and/or bystanders. It further compromises the acceptance of this system by the FHWA. Please keep these instructions for later use and reference by anyone involved in the assembly of the product.



Warning: Ensure that all of the REACT 350[®] II system Warnings, Cautions, and Important Statements within the REACT 350[®] II system Manual are completely followed. Failure to follow this warning could result in serious injury or death in the event of a collision.

Recommended Safety Rules for Assembly

*** Important Safety Instructions ***

This Manual must be kept in a location where it is readily available to persons who are skilled and experienced in the assembly, maintenance, or repair of the REACT 350[®] II system. Additional copies of this Manual are immediately available from Energy Absorption Systems by calling (888) 323-6374 or by email at customerservice@energyabsorption.com. This Manual may also be downloaded directly from the websites indicated below. Please contact Energy Absorption Systems if you have any questions concerning the information in this Manual or about the REACT 350[®] II system.

Always use appropriate safety precautions when operating power equipment, mixing chemicals, and when moving heavy equipment or the REACT 350[®] II system components. Gloves, safety goggles, safety-toe shoes, and back protection shall be used.

Safety measures incorporating traffic control devices specified by the highway authority must be used to provide safety for personnel while at the assembly, maintenance, or repair site.

Safety Symbols

This section describes safety symbols that may appear in the REACT 350[®] II System Manual. Read the Manual for complete safety, assembly, operating, maintenance, repair, and service information.

<u>Symbol</u>	<u>Meaning</u>
---------------	----------------



Safety Alert Symbol: Indicates Danger, Warning, or Caution. Failure to read and follow the Danger, Warning, Safety, or Caution indicators could result in serious injury or death to the workers and/or bystanders.

Warnings and Cautions

Read all instructions before assembling, maintaining, or repairing the REACT 350[®] II system.



Warning: Do not assemble, maintain, or repair the REACT 350[®] II system until you have read this Manual thoroughly and completely understand it. Ensure that all Warnings, Cautions, and Important statements within the Manual are completely followed. Please call Energy Absorption Systems at (888) 323-6374 if you do not understand these instructions. Failure to follow this warning could result in serious injury or death in the event of a collision.



Warning: Safety measures incorporating appropriate traffic control devices specified by the highway authority must be used to protect all personnel while at the assembly, maintenance, or repair site. Failure to follow this warning could result in serious injury or death in the event of a collision.



Warning: Use only Energy Absorption Systems parts that are specified herein for the REACT 350[®] II for assembling, maintaining, or repairing the REACT 350[®] II system. Do not utilize or otherwise comingle parts from other systems even if those systems are other Energy Absorption Systems or Trinity Highway Products systems. Such configurations have not been tested, nor have they been accepted for use. Assembly, maintenance, or repairs using unspecified parts or accessories is strictly prohibited. Failure to follow this warning could result in serious injury or death in the event of a vehicle impact with an UNACCEPTED system.



Warning: Do NOT modify the REACT 350[®] II system in any way. Failure to follow this warning could result in serious injury or death in the event of a collision.



Warning: Ensure that the REACT 350[®] II system and delineation used meet all federal, state, specifying agency, and local specifications. Failure to follow this warning could result in serious injury or death in the event of a collision.



Warning: Ensure that your assembly meets all appropriate Manual on Uniform Traffic Control Devices (MUTCD) and local standards. Failure to follow this warning could result in serious injury or death in the event of a collision.

Limitations and Warnings

Energy Absorption Systems, in compliance with the National Cooperative Research Highway Program 350 (NCHRP Report 350) "Recommended Procedures for the Safety Performance of Highway Safety Features", contracts with FHWA approved testing facilities to perform crash tests, evaluation of tests, and submittal of results to the Federal Highway Administration for review.

The REACT 350[®] II system was tested to meet the impact criteria, requirements, and guidelines of NCHRP Report 350 TL-3. This test typically evaluates product performance by closely simulating actual impacts selected by NCHRP involving a typical range of vehicles on our roadways, from lightweight cars (approx. 820 kg [1800 lb.]) to full size pickup trucks (approx. 2000 kg [4400 lb.]) as selected and specified by the FHWA. A product can be certified for multiple Test Levels. The REACT 350[®] II is certified to the Test Level shown below:

Test Level 3: 100 km/h [62 mph]

These FHWA directed tests are not intended to represent the performance of systems when impacted by every vehicle type or every impact condition existing on the roadway. This system is tested only to the criteria of NCHRP 350 as approved by FHWA.

Energy Absorption Systems does not represent nor warrant that the results of these controlled tests show that vehicle impacts with the products in other conditions would necessarily avoid injury to person(s) or property. Impacts that exceed criteria capabilities of the product may not result in acceptable impact performance as outlined in NCHRP Report 350, relative to structural adequacy, occupant risk, and vehicle trajectory. Energy Absorption Systems expressly disclaims any warranty or liability for injury or damage to persons or property resulting from any impact, collision, or harmful contact with products, other vehicles, or nearby hazards or objects by any vehicle, object or person, whether or not the products were assembled with the assistance, or in the presence, of Energy Absorption Systems representatives or by third parties.

The REACT 350[®] II system is intended to be assembled, delineated, and maintained in accordance with specific state and federal guidelines. It is important to select the most appropriate product configuration for a site. The customer should be careful to properly select, assemble, and maintain the product. Careful evaluation of the site geometry, vehicle population type, speed, traffic direction, and visibility are some of the elements that require evaluation in the proper selection of a safety appurtenance. For example, assemblies on curbs have not been tested, nor evaluated and should not be permitted. Before assembly of this system at any location, these issues need to be fully discussed with the appropriate highway authority planning and specifying the installation.

After an impact occurs, the product should be restored to its original condition as soon as possible. When a reusable product is impacted, it is still necessary to restore the product to its original length and inspect all the components as necessary. Whether a product is reusable or not is the sole discretion of the highway authority.

It is absolutely critical that the entire system be inspected frequently and maintained by the user of the system. Failure to do so may render the system ineffective and incapable of performing as tested.

System Overview

The REACT 350[®] II system, through crash testing, has been shown to be a potentially reusable, redirective, non-gating, crash cushion for hazards up to 914 mm (3') wide. After those impacts observed within NCHRP 350 criteria, it has been observed that, potentially, the entire bulk of the system can be reused. What constitutes a potentially reusable highway product should only be determined by a trained engineer, experienced in highway products, directed by the appropriate highway authority.

When impacted under NCHRP 350* criteria, this system is capable of shielding specified hazards up to 914 mm (3') wide. It consists of a series of "smart plastic" Cylinders attached to a steel Base Track. The term "smart plastic" refers to the memory characteristics of the Cylinders. After a head-on impact as described in NCHRP 350, the REACT 350[®] II system has the potential to recover a major portion of its shape, position, and energy absorbing capability.

The REACT 350[®] II system utilizes various Cylinder wall thicknesses to accommodate both light cars and heavier, high-center-of-gravity vehicles.

Two backup options are available to further meet specific requirements of each location. A Self-Contained Backup is available, or the REACT 350[®] II system can be mounted to a new or existing Concrete Backup. In some locations, either Backup type may be applicable.

*NCHRP Report National Cooperative Highway Research Program Report 350

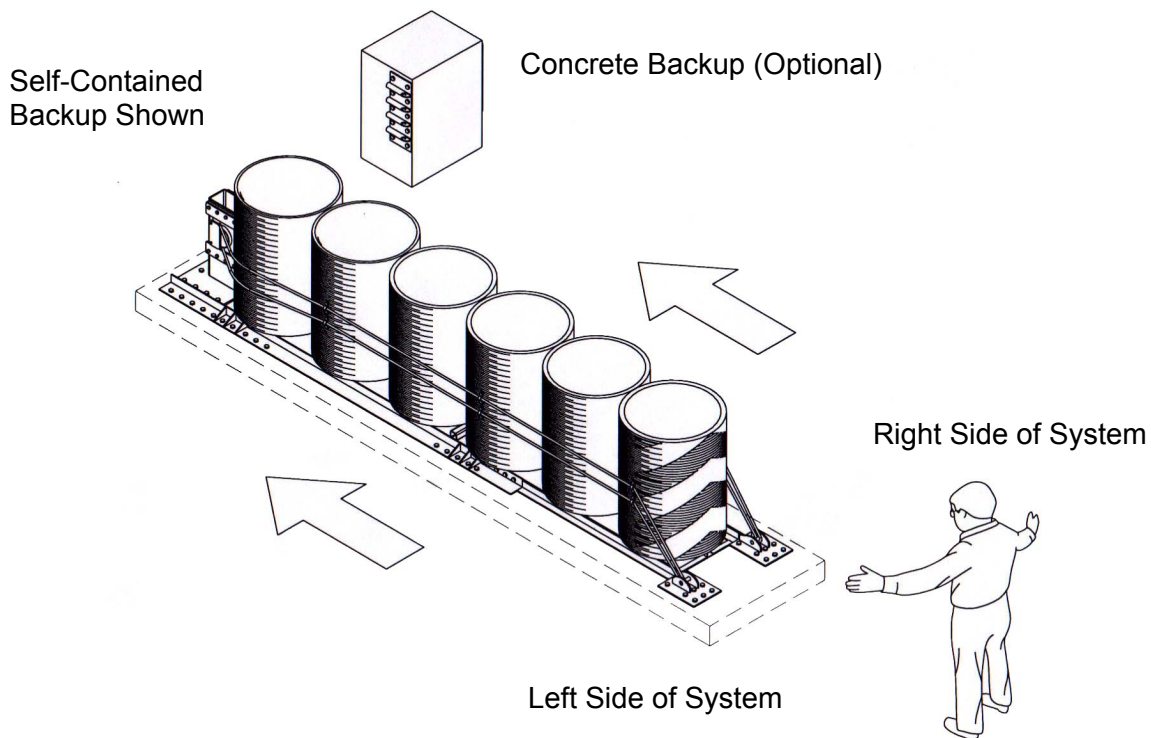

Figure 1 - REACT 350[®] II with Self-Contained Backup

Assembly

Recommended Tools

Documentation

- Manufacturer's Instructional Manual
- Manufacturer's Drawing Package

Cutting equipment

- Grinder/Hacksaw or Torch
- Rebar cutting bit
- Rotary Hammer Drill
- 22 mm (7/8") x 178 mm (7") Concrete Drill Bit (Double Fluted)
- 19 mm (3/4") x 178 mm (7") Concrete Drill Bit (Double Fluted)

Note: Energy Absorption Systems recommends using double fluted drill bits to achieve optimum tensile strength when applying the MP-3[®] anchoring system. That decision must be confirmed with the highway authority authorizing the assembly so it is anchored to their specification.

Hammers

- Sledgehammer

Wrenches

- Heavy duty impact wrench
- 1/4", 5/16", 3/8", 3/4", 1 7/8" sockets
- 3/4", 1 1/16", 1 1/8", 1 1/4" Deep Hex-head Sockets
- Ratchet and extensions for above sockets
- Standard adjustable wrench
- 1 1/16", 1 1/8", 1 1/4", 9/16", 5/8" combination wrenches
- Large Pipe Wrench

Screwdrivers

- Screw gun or standard drill with adapter chuck for small screws/bolts
- Flat Screwdriver
- Phillips Screwdriver

Personal protective equipment

- Safety Glasses
- Gloves
- Apron for MP-3[®] application
- Safety-Toe Shoes

Miscellaneous

- Traffic control equipment
- Lifting and moving equipment (A lifting device is preferred although a forklift can be used.) Minimum 2722 kg [6,000 lb.] capacity required. Do not lift overhead.
- Compressor (100 psi) and Generator (5 KW)
- Long pry bar
- Drift pin
- Tape measure 7.5 m (25')
- Chalk line
- Nylon bottle brush for cleaning drilled holes
- Rags, water, and solvent for touch-up

Note: The above list of tools is a general recommendation. Depending on specific site conditions and the complexity of the assembly specified by the appropriate highway authority, additional or fewer tools may be required. Decisions as to what tools are needed to perform the job are entirely within the discretion of the specifying highway authority and the authority's selected contractor performing the assembly of the system at the authority's specified site.

Know Your REACT 350[®] II System

For specific assembly, maintenance, or repair details refer to the state or specifying agency's standard drawing(s) and/or Energy Absorption Systems standard layout drawings.

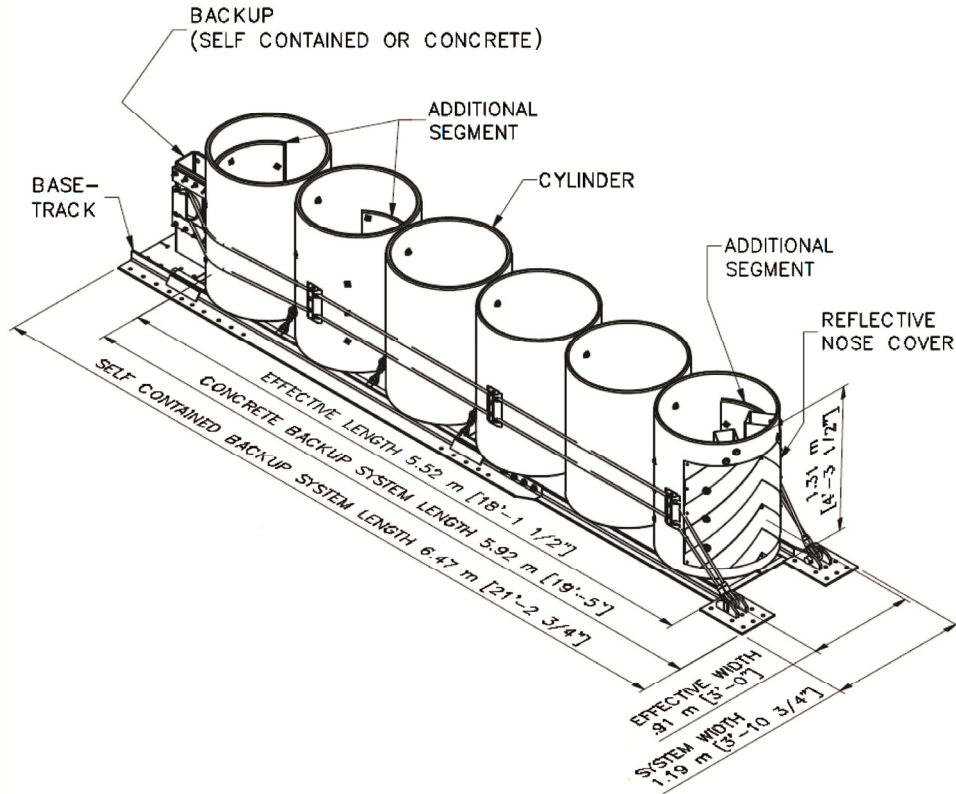

Figure 2

System Size

	Backup	
	Self-Contained	Concrete
Effective Length	5.52 m [18'-1 1/2"]	5.52 m [18'-1 1/2"]
System Length	6.47 m [21'-2 3/4"]	6.02 m [19'-9"]
Effective Width	.91 m [3'-0"]	
System Width	1.19 m [3'-10 3/4"]	
Height	1.31 m [4'-3 1/2"]	

Model Number Description

Backup Type	
B	C
Self-Contained steel backup	Concrete Backup with Side Mount Anchors
Typical hazard width *203 mm [8"]	Max. hazard width 914 mm [36"]

*See "Hazard Width" on Page 13 for wider hazards.

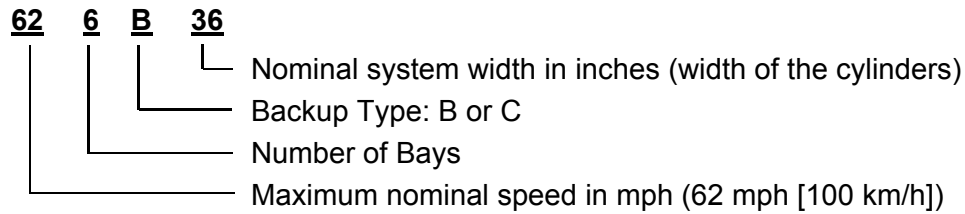

Number of Bays

A Bay consists of one Cylinder. The terms Bay and Cylinder may be used interchangeably. The Cylinder at the front of the system (traffic end) is always Bay 1, and each subsequent bay is sequentially numbered to the rear of the system (hazard end).

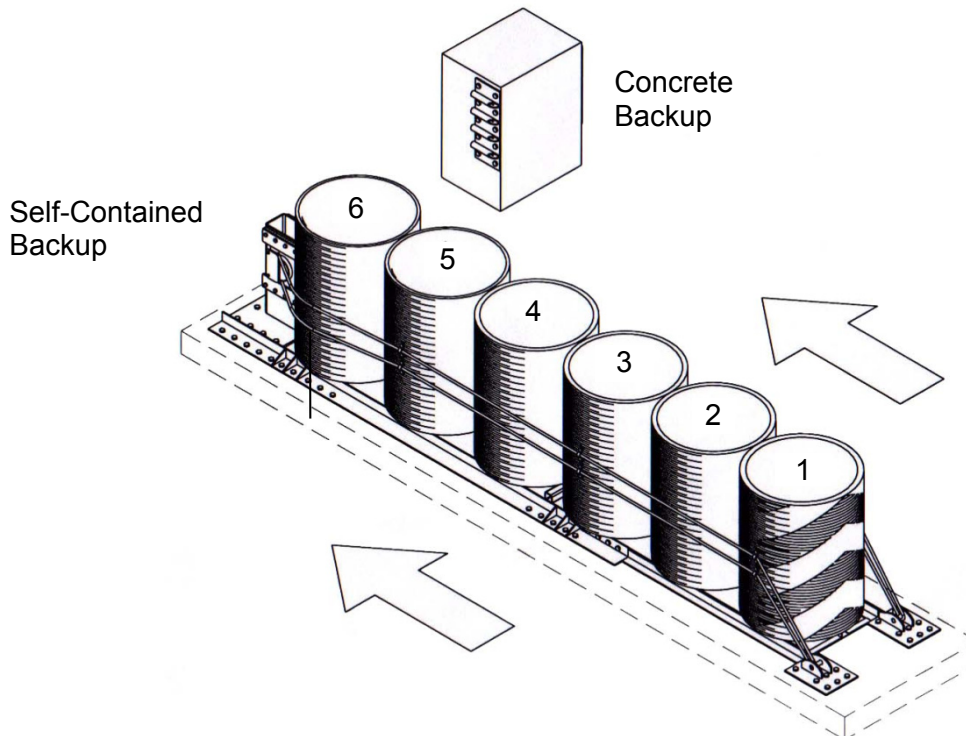

Figure 3
Number of Bays

Backup Type

It is important to fully understand the limitations of each backup type so the correct REACT 350® II system is chosen for each location.

The REACT 350® II system is available with a Self-Contained Backup or may be attached to a Concrete Backup. Refer to Figures 4a and 4b, along with the backup assembly drawings, to determine which type of backup is appropriate.

Self-Contained Backup

REACT 350® II System with a Self-Contained “steel tube” Backup require two cables, one cable on each side of the Cylinders. These cables begin at the front of the system, travel through the Cable Guides on the Cylinders, loop around the backup structure, travel back through the Cable Guides, and terminate at the front of the system.

Concrete Backup

REACT 350® II System with a Concrete Backup requires four cables. Two cables on each side of the Cylinders begin at the Side Anchor Plates, travel through the Cable Guides on the Cylinders, loop around the pin on the Front Anchor Plates, travel back through the Cable Guides, and terminate at the Side Anchor Plates.

Existing concrete structures may serve as backups for REACT 350® II system provided they meet specific size and strength requirements.

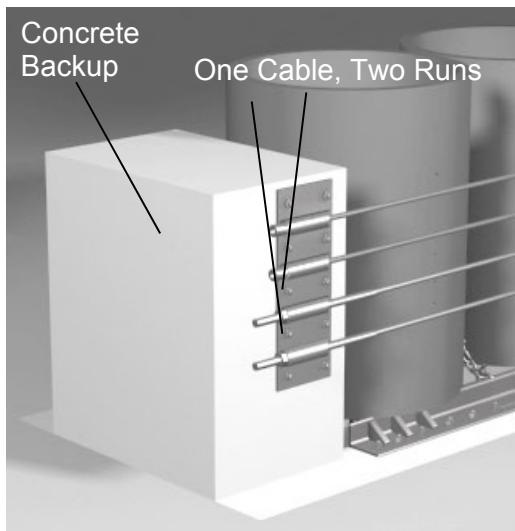

Figure 4a

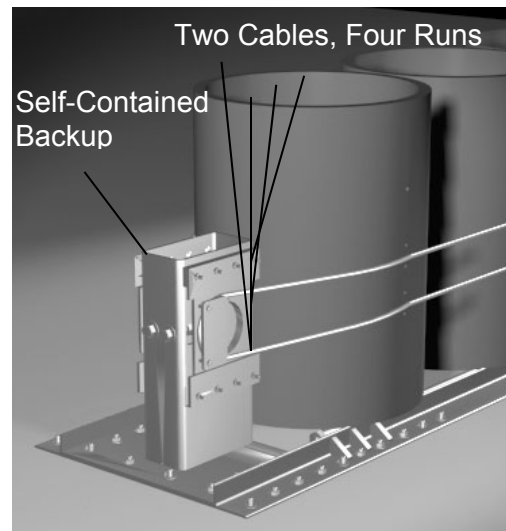

Figure 4b

System Design

Self-Contained Backup

The REACT 350[®] II system with a Self-Contained Backup is intended to minimize assembly time. This type of system arrives at the site fully assembled. The assembly crew needs only to lift and place the system in front of the barrier then drill and set the anchors. Refer to the "Assembly" section on Page 22 for a complete list of instructions.

Hazard Width

Generally, the REACT 350[®] II system with a Self-Contained Backup can shield obstacles to 203 mm [8"] wide in a gore application. This type of system can also shield wider hazards in non-gore and bidirectional traffic locations (See "Bidirectional Traffic" on Page 14 and "Offsetting the System" on Page 15). Please contact Energy Absorption Systems for additional wide hazard information (See Page 3).

When shielding median barriers (813 mm [32"] tall safety shape), a Self-Contained Backup may be used if the base or "toe" of the barrier is tapered to a total width of 330 mm [13"] (See Figure 5).

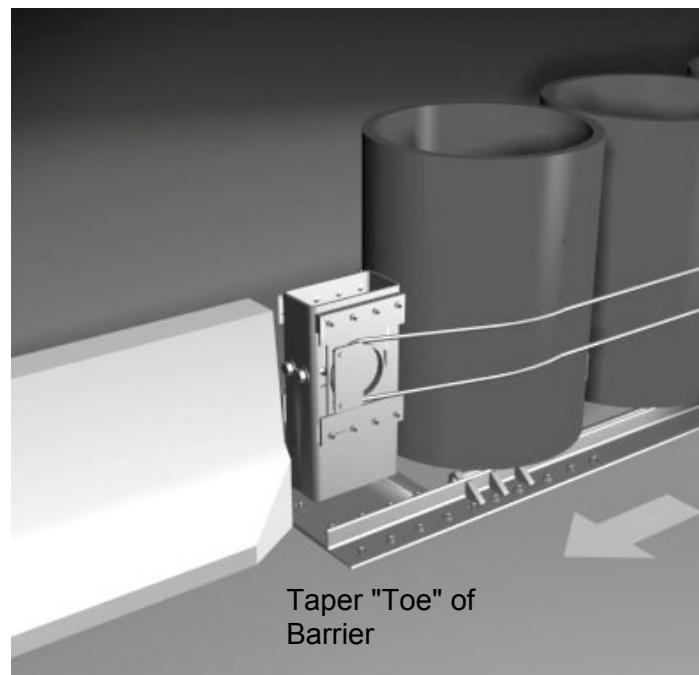

Figure 5
Tapered Barrier

Guardrail Attachment

Hardware is available to mount W-beam guardrail or a safety shaped barrier to the Self-Contained Backup of the REACT 350[®] II system. A folded Transition Plate and W-beam connector can mount to either or both sides of the backup assembly (See Figure 6). If bidirectional traffic is present, special post spacing, rail, and rub-rail will be required for the guardrail.

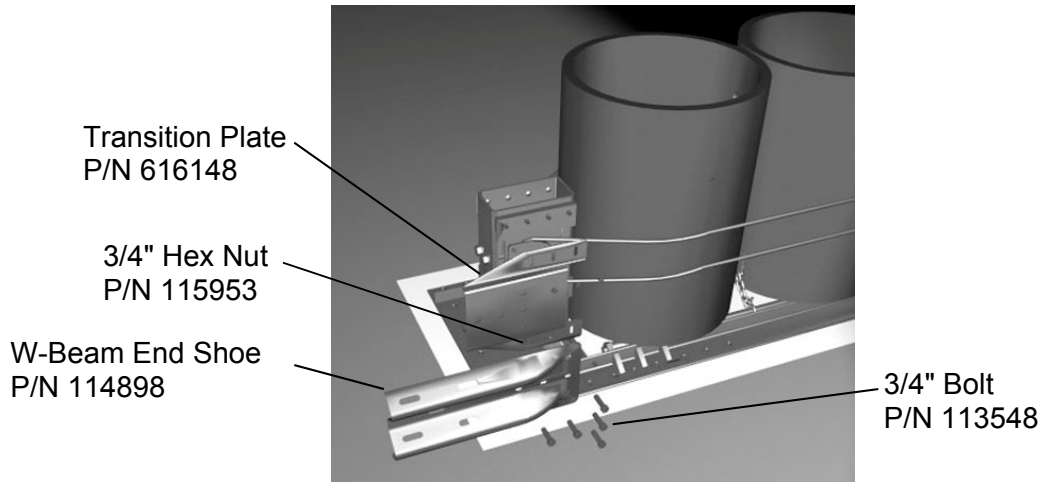

Figure 6
Guardrail Attachment Hardware

Bidirectional Traffic

If bidirectional traffic (vehicles traveling opposite directions on either side of the system) is present, special consideration needs to be taken when placing the system. It is important that the Self-Contained Backup does not become a hazard to the reverse direction traffic. If a system is placed in a location where traffic will be approaching from the rear of the system, transition hardware may be required.

Optionally, if space permits, the REACT 350[®] II system may be offset so that the backup structure is shielded by the hazard (See "Offsetting the System" on Page 15). Guardrail transition hardware may also be used.

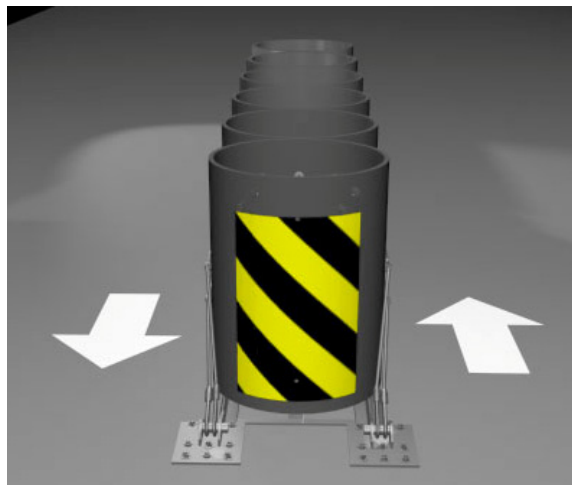

Figure 7
Bidirectional Traffic

Offsetting the System

If space permits, REACT 350[®] II system, with a Self-Contained Backup, may be offset from the center of the hazard. Offsetting may be necessary for two reasons:

- 1) To shield a hazard wider than 200 mm [8"]
- 2) If bidirectional traffic is present

When offsetting the system, align the vertical face of the Backup structure with the face of the barrier (See Figure 8). With this method, REACT 350[®] II system with Self-Contained Backup may shield hazards up to 610 mm [24"].

If a wider hazard is present or if bidirectional traffic is present, a Concrete Backup may be required. Contact Energy Absorption Systems Customer Service Department for further information.

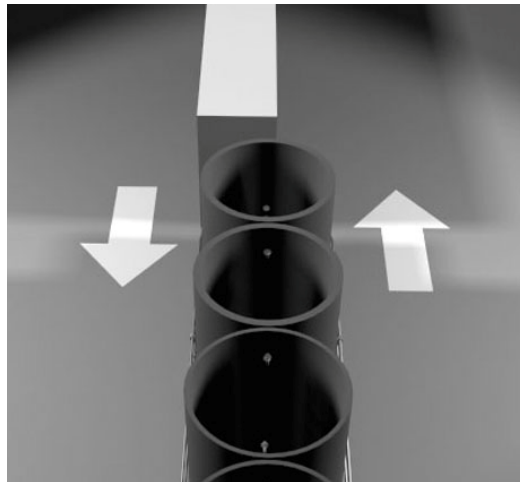

Figure 8

Offsetting the system

Concrete Backup

The REACT 350[®] II system is also intended to mount directly to a new or existing Concrete Backup. This type of system requires slightly more assembly time, as the cables must be assembled on site (See the "Assembly" section "Systems with Concrete Backups" on Page 26 for a complete list of instructions).

Existing Concrete Backups must be a minimum of 1000 mm [40"] high, 610 mm [24"] long, and 762 mm [30"] to 914 mm [36"] wide, with 28-day strength of 28 MPa [4000 psi] and fully reinforced.

If your existing structure does not meet these minimums, special hardware and designs may be available for them. Contact Energy Absorption Systems Customer Service Department if you have questions concerning Concrete Backup requirements (See Page 3).

Hazard Width

The REACT 350[®] II system with a Concrete Backup may be specified to protect obstacles up to 914 mm [36"] wide. The backup must be 762 mm [30"] to 914 mm [36"] wide to use standard side anchor hardware.

Bidirectional Traffic

If bidirectional traffic (vehicles traveling opposite directions on either side of the system) is present, special consideration needs to be taken when placing the system.

It is important for the highway design engineer and the assembler to ensure that the Concrete Backup itself does not become a hazard to the reverse direction traffic. If the system is placed in a location where traffic will be approaching from the rear of the system, the Backup should not protrude beyond the hazard being shielded. Concrete tapering may be required.

Also, an additional standard Side Anchor Plate should be rotated 180 degrees and placed behind the first anchor plate (See Figure 9). In this case, the backup must be 762 mm [30"] long.

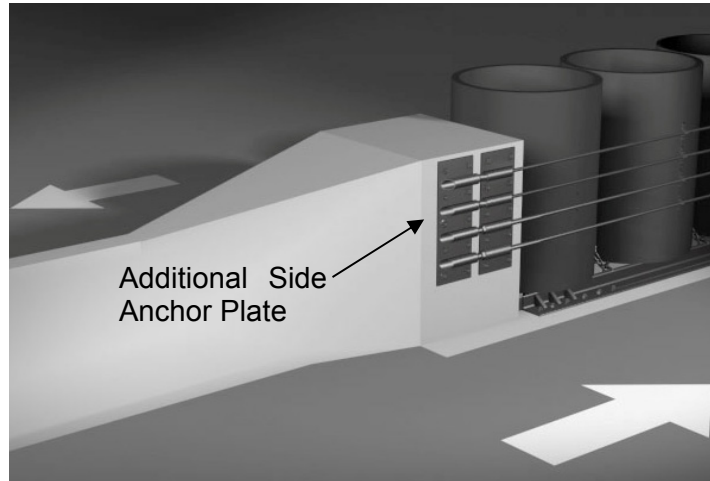

Figure 9

Standard Anchor Plate with Concrete Backup

Foundation/Anchoring

Concrete Installations

For concrete installations, the REACT 350[®] II system should be installed only on an existing or freshly placed and cured concrete base (28 MPa [4000 psi] minimum). Orientation of the concrete base and the attenuator must comply with the project plans or as otherwise determined by the resident project engineer or appropriate highway authority.

Recommended dimension and reinforcement specifications for new concrete pads can be found on the standard drawings.

Asphalt Installations

For asphalt installations in construction zones, REACT 350[®] II system may only be assembled with a Tension-Strut Backup. Assemblies on asphalt must provide a minimum of 76 mm [3"] layer of asphalt over a minimum of 76 mm [3"] layer of Portland Cement concrete, 152 mm [6"] layer of asphalt over 152 mm [6"] layer of subbase, or 203 mm [8"] layer of asphalt with no subbase. 460 mm [18"] threaded rods, installed with the two-part MP-3[®] grout, must be used for these foundations.



Important: Systems mounted on asphalt must be replaced and mounted on fresh, undisturbed asphalt if more than 10% of anchors are found to be loose, broken, or show signs of pull out. If 10% or fewer anchors are damaged, replace the damaged anchors in the existing asphalt. Anchor bolts used on systems mounted on asphalt must be inspected every 6 months. See Post Impact Instructions and Maintenance and Repair instructions in the REACT 350[®] II Assembly Manual for details.

The REACT 350[®] II system may be installed on any of the following foundations using the specified anchorage:

Foundation A: Concrete Pad or Roadway

Foundation: 150 mm [6"] minimum depth Portland Cement Concrete (P.C.C.)

Anchorage: MP-3[®] with 180 mm [7"] studs 140 mm [5 1/2"] embedment

Foundation B: Asphalt over P.C.C.

Foundation: 76 mm [3"] minimum asphalt concrete (A.C.) over 76 mm [3"] minimum P.C.C.

Anchorage: Length of anchor required is 460 mm [18"] 420 mm [16 1/2"] embedment

Foundation C: Asphalt over Subbase

Foundation: 150 mm [6"] minimum A.C. over 150 mm [6"] minimum Compacted Subbase (C.S.)

Anchorage: MP-3 with 460 mm [18"] studs 420 mm [16 1/2"] embedment

Foundation D: Asphalt Only

Foundation: 200 mm [8"] minimum A.C.

Anchorage: MP-3 with 460 mm [18"] studs - 420 mm [16 1/2"] embedment

Foundation Specifications

for Foundations A, B, C, and D mentioned above:

A. C. (Asphalt Concrete)

AR-4000 A. C. (per ASTM D3381 '83) 3/4" Maximum, Medium (Type A or B) aggregate

Sieve Size	Operating Range (%) Passing
1"	100
3/4"	95-100
3/8"	65-80
No. 4	49-54
No. 8 3	6-40
No. 30 1	8-21
No. 200	3-8



Caution: Walk-up inspections are recommended at least once every six months for installations on asphalt.

P.C.C. (Portland Cement Concrete)

Stone aggregate concrete mix

4000 psi minimum compressive strength

(Sampling per ASTM C31-84 or ASTM C42-84a, testing per ASTM C39-84)

C.S. (Compacted Subbase)

150 mm [6"] minimum depth 95% compaction

Class 2 aggregate

Sieve Size	Moving Average % Passing
3"	100
2 1/2"	90-100
No. 4	40-90
No. 200	0-25

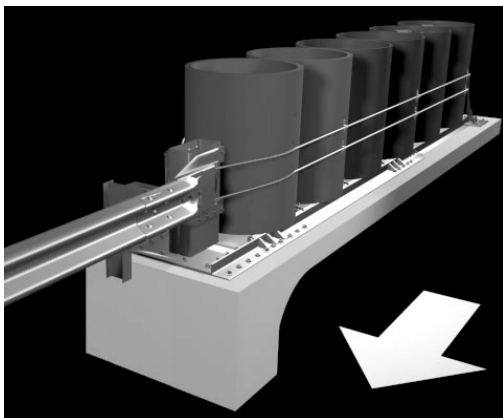

Figure 10a Below-Grade Anchor Block

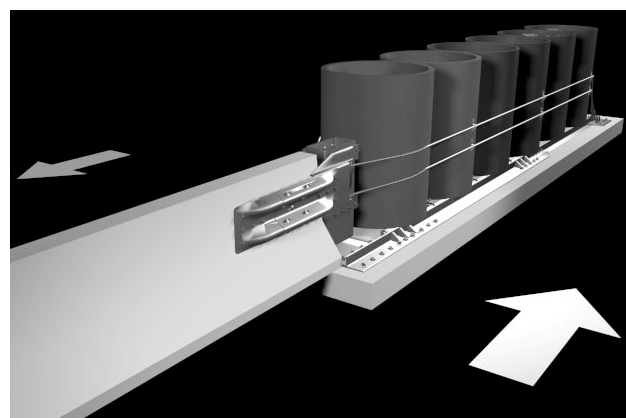

Figure 10b - Anchor Block Not Needed

Foundation/Anchoring Assistance

Contact Energy Absorption Systems Customer Service Department if you would like input as to your specific application. Proper model selection is essential to the performance of the REACT 350[®] II system. You will need to answer the following questions:

1. Are curbs, islands, or elevated objects (delineators or signs) present at the site? What height and width are they? All curbs and elevated objects should be removed. Curbs should be removed from behind the backup to approximately 15 m [50'] in front of the REACT 350[®] II System. Any curbs that must remain should be 102 mm [4"] maximum and be mountable. Signs should not interfere with the system's ability to collapse. Generally, a vehicle should not interact with two appurtenances at the same time. Allow adequate spacing.
2. If the deployment site is a gore area (place where two roads diverge), what is the angle of divergence?
3. What is the general geometry of the site? Include the roadway for 150 m [500'] in front of the hazard, so traffic patterns can be visualized.
4. Is there an existing guardrail or median barrier at the site?
5. What is the width of the hazard to be protected?
6. Will there be traffic approaching from the rear of the system? Is the system in a two-way traffic situation with traffic going in opposite directions on either side of the system? Or, is the system on the side of the road where cross over traffic is a concern? If so, a transition from the hazard to the rear of the system may be necessary to prevent a vehicle from interacting with the rear of the system (See "Bidirectional Traffic" on Pages 13 and 15).
7. Are there any other unique features at the site that may affect the positioning or performance of the REACT 350[®] II system? See "Other Factors That May Affect Your Specification on Page 20.

Other Factors That May Affect Your Specification

1. The existence of drain inlets or buried culvert pipe.
2. Junction boxes or other appurtenances located near the hazard.
3. Insufficient space for the length of system preferred.
4. The location and movement of expansion joints.
5. Breaking cross-slopes under or near the proposed assembly or severe cross-slope under the system. Provide leveling to 8% maximum.

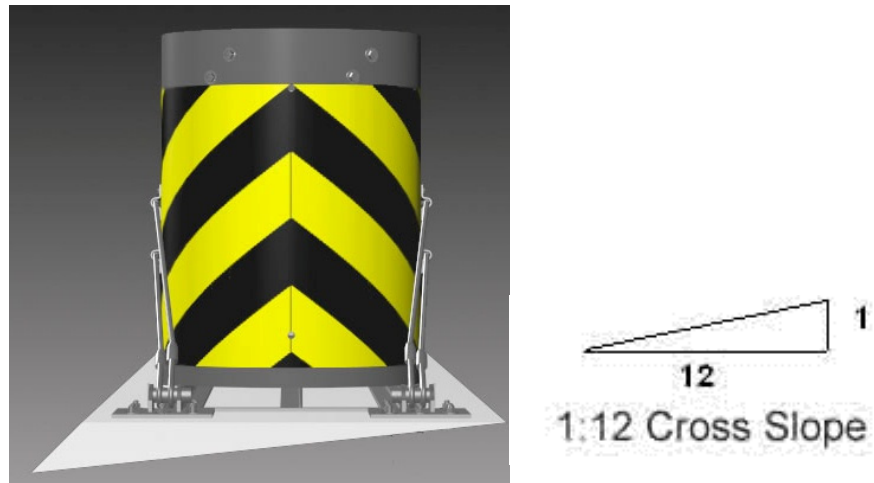

Figure 11 - 1:12 Cross-Slope



Warning: The existence of any cross slopes in excess of 8% or curbs may create an untested effect on the impacting vehicle.

Joints

The REACT 350[®] II system may span longitudinal joints; however, custom hardware may be required.

The REACT 350[®] II system may also span a transverse joint if the joint falls under the front section of Base Track. In this case, the front section of Base Track should be cut after assembly so as not to span the joint with structural steel. Never cut the rear section of Base Track. The joint movement must be limited to 38 mm [1.5"].

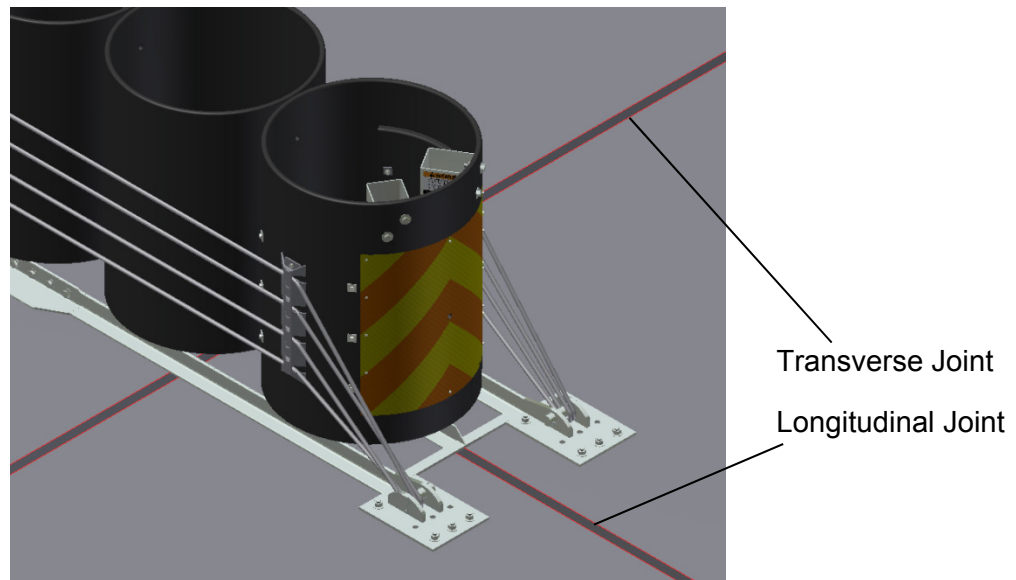

Figure 12 - Longitudinal or Transverse Joints

Inspect Shipment

Before assembling the REACT 350[®] II system at a specified location, check the received parts against the shipping list supplied with the system. Make sure all parts have been received. The System is shipped assembled. All assembly hardware can be found in the last Cylinder. The Pullout Assembly should be stored for post impact use.

Assembly Procedures

Note: The drawing assembly package provided with the REACT 350[®] II system must be used with these instructions for proper assembly and should take precedence over these general instructions.

1) Deploy Traffic Control

A traffic control plan appropriate to the complexity of the project should be prepared and understood by all parties before the REACT 350[®] II system is assembled. Follow the plan set forth by the highway authority specifying the use of this system.

Deploy the appropriate work zone safety devices prior to beginning the assembly and keep them present through all phases of deployment.



Warning: The correct safety equipment and traffic management system approved by the requisite highway authority must be used as required for any assembly using the REACT 350[®] II system.

2) Determining the Base Point & Centerline

Typically the base point of the REACT 350[®] II system will be the midpoint of the hazard at its front face. This may change if bidirectional traffic or expansion joints are present (See "Offsetting the System" on Page 15).

Extend a chalk line from the base point, perpendicular to the hazard face, or as determined by project engineer, to a distance greater than the maximum length of the REACT 350[®] II system (refer to the drawings provided). This chalk line will become the centerline for the REACT 350[®] II system (See Figure 13).

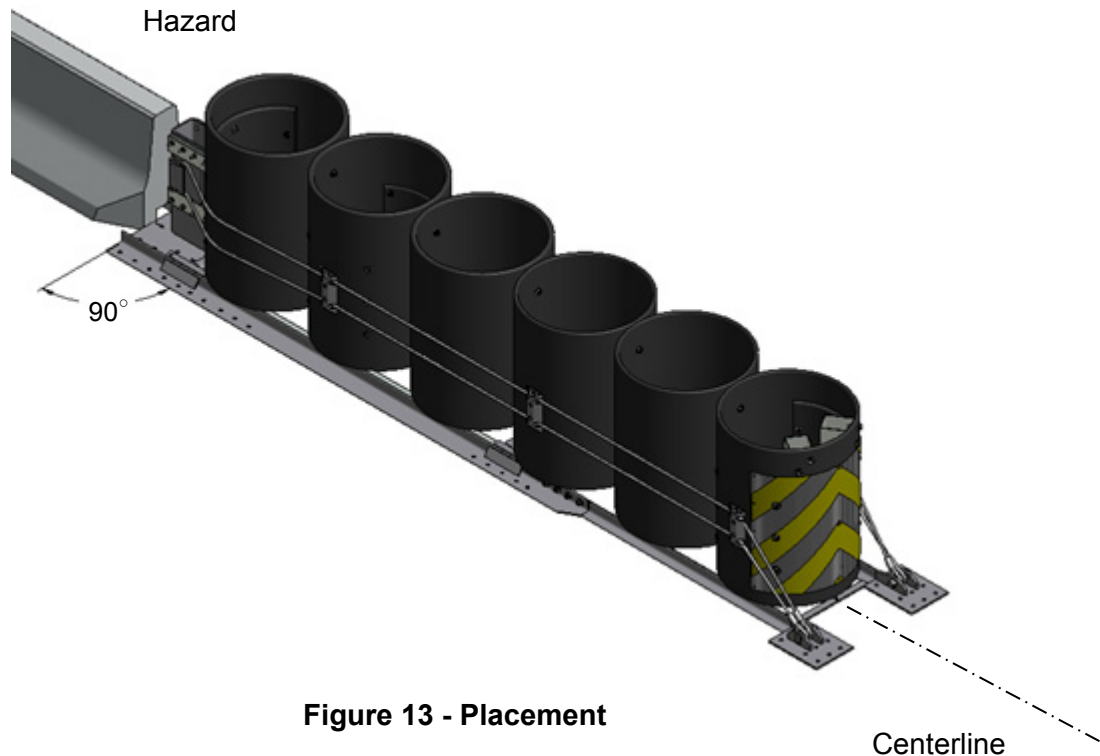

Figure 13 - Placement

3) Lifting/Placing the System

Mark the centerline on the front and rear of the Base Track. Use the Lifting Eyes located on the Middle Rail of the Rear Base Track (look down into the Cylinders) to lift the REACT 350[®] II system into place (See Figure 14).

Use fixed-length slings with a 2722 kg [6,000 lb.] minimum capacity. Fixed slings will prevent the System from tipping. Do not lift overhead. Measure from the centerline to ensure that the REACT 350[®] II system is centered and positioned at the proper angle. The steel Base Track will rest flush against the hazard face for assemblies that do not require transitions.

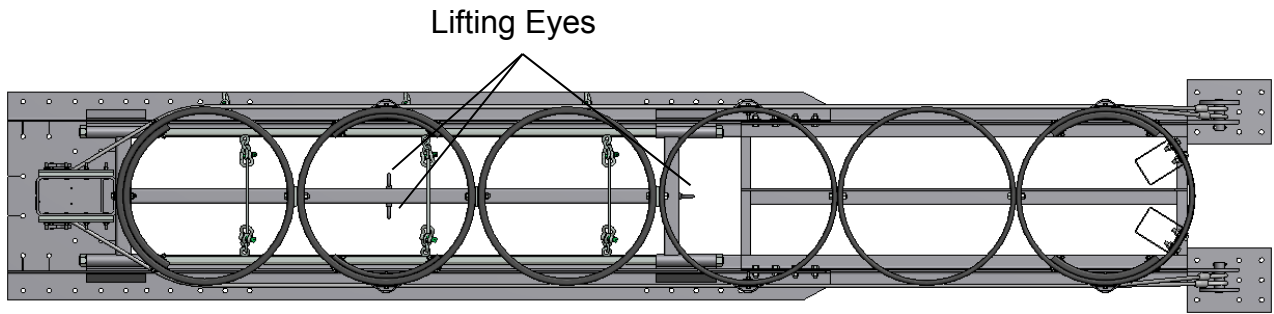

Figure 14 - Lifting Eye Location



Warning: Ensure the hoist device is properly rated to lift the REACT 350® II system.

For Self-Contained Backup assemblies requiring transition hardware to concrete wall or safety shape barrier (P/N 616120), the steel Base Track should be 127 mm [5"] forward of the hazard face (See Figure 15).

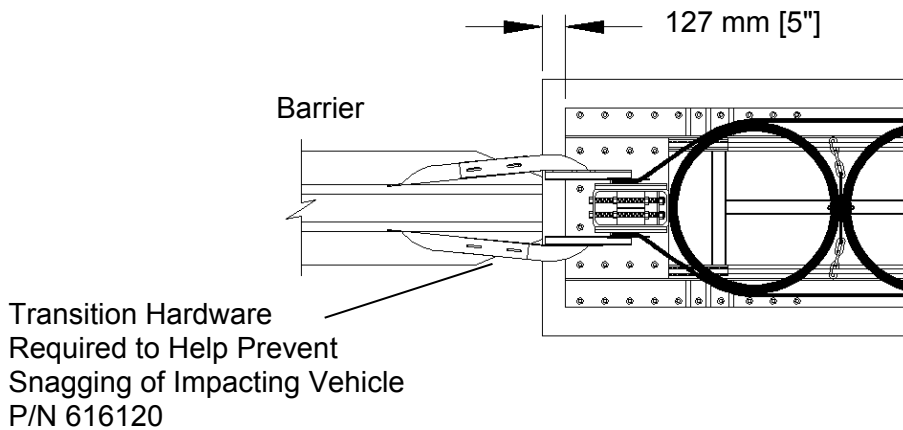

Figure 15 – Transition Hardware

Systems with Self-Contained Backups

Note: For Systems with Concrete Backups, please skip to Page 26.

4) Drill and Set Anchors

Use the holes in the Base Track as a template to locate and drill holes, 22 mm [7/8"] diameter x 140 mm [5 1/2"] deep into the concrete pad or roadway surface (see Figure 16). All holes in Base Plate must be used to anchor the REACT 350® II System to the foundation. Use vertical MP-3® kits to attach 3/4" diameter x 7 1/2" long studs using instructions included with kit. Refer to the MP-3® Polyester Anchoring System section on Page 34 for step-by-step instructions.

After grout has hardened, use 3/4" flat washers and nuts provided with kit to anchor base track to foundation.



Warning: All holes in Base Plate must be used to anchor the REACT 350® II system to the foundation.



Warning: Once the grout has hardened, see Table B on Page 36 for hardening times, torque nuts to 165 N-m [120 ft-lb].

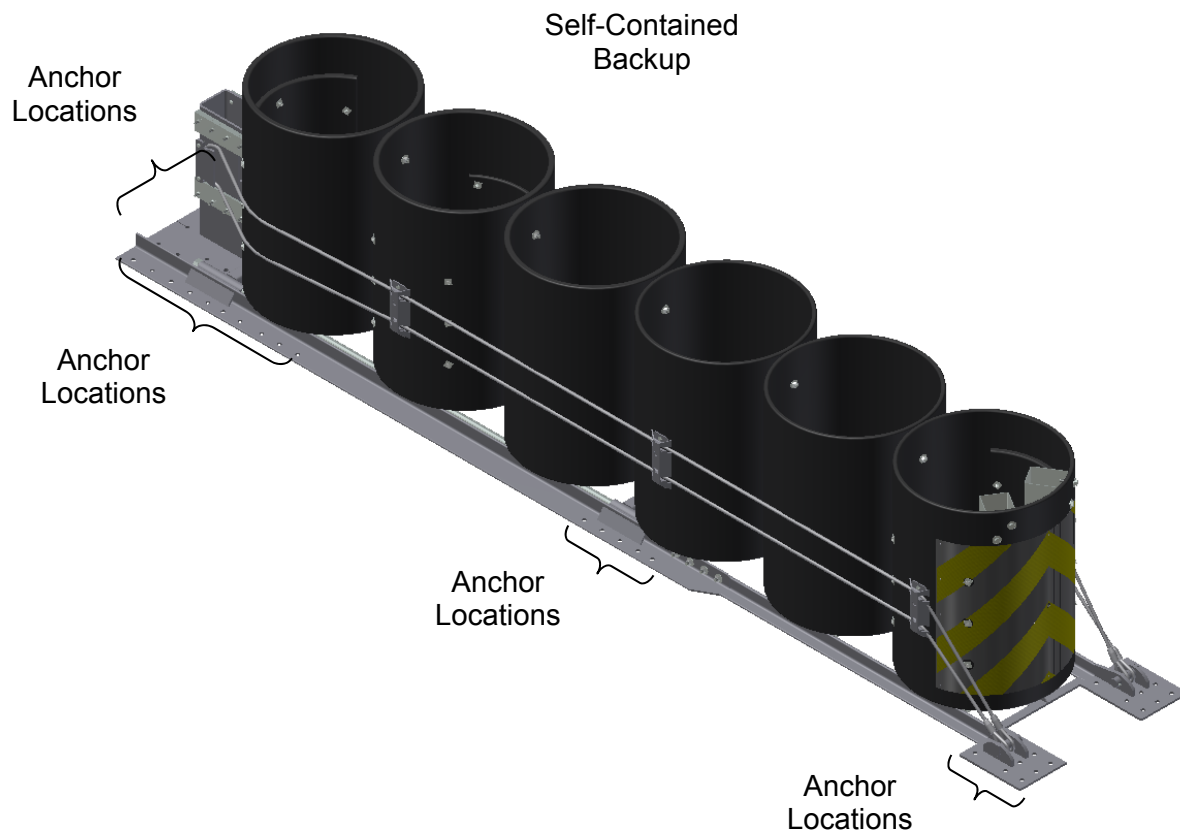

Figure 16 - Anchoring the System - Self-Contained Backup

5) Tension Restraining Cables

Use the two adjusting nuts at the rear of the Backup to tension the cables (See Figure 17). When properly tensioned, the cables should not deflect more than 75 mm [3"] with 45 kg [100 lb.] downward pressure.

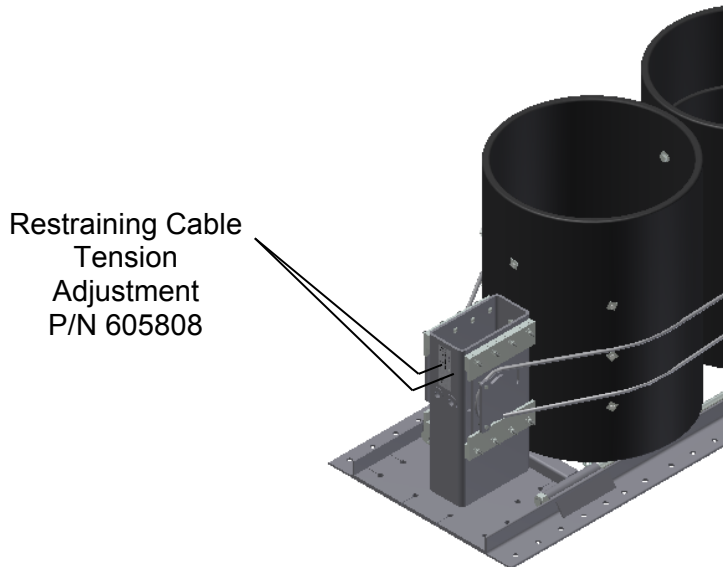

Figure 17 - Tension Adjustment (Self-Contained Backup)

Concrete Backups

1) Rear Cylinder Attachment

Use the holes in the Rear Cylinder as a template to locate and drill two holes, 22 mm [7/8"] diameter x 140 mm [5 1/2"] deep into the Concrete Backup (See Figure 18). Use horizontal MP-3[®] kit to attach 3/4" diameter x 7 1/2" long studs using instructions included with kit. Refer to MP-3[®] Polyester Anchoring System on Page 34 for step-by-step instructions. After grout has hardened, use 3/4" nuts and flat washers included with MP-3[®] kits to attach Cylinder Assembly to Backup as shown in Figure 18.

2) Drill and Set Anchors

Use the holes in the Base Track as a template to locate and drill holes, 22 mm [7/8"] diameter x 140 mm [5 1/2"] deep into the concrete pad or roadway surface (See Figure 18). Use Vertical MP-3[®] kits to attach 3/4" diameter x 7 1/2" long studs using instructions included with kit. Refer to MP-3[®] Polyester Anchoring System on Page 34 for step-by-step instructions. After grout has hardened, use 3/4" flat washers and nuts provided with kit to anchor base track to foundation.



Warning: All holes in Base Plate must be used to anchor the REACT 350[®] II system to the foundation.



Warning: Once the grout has hardened, see Table B on Page 36 for hardening times, torque nuts to 165 N-m [120 ft-lb].

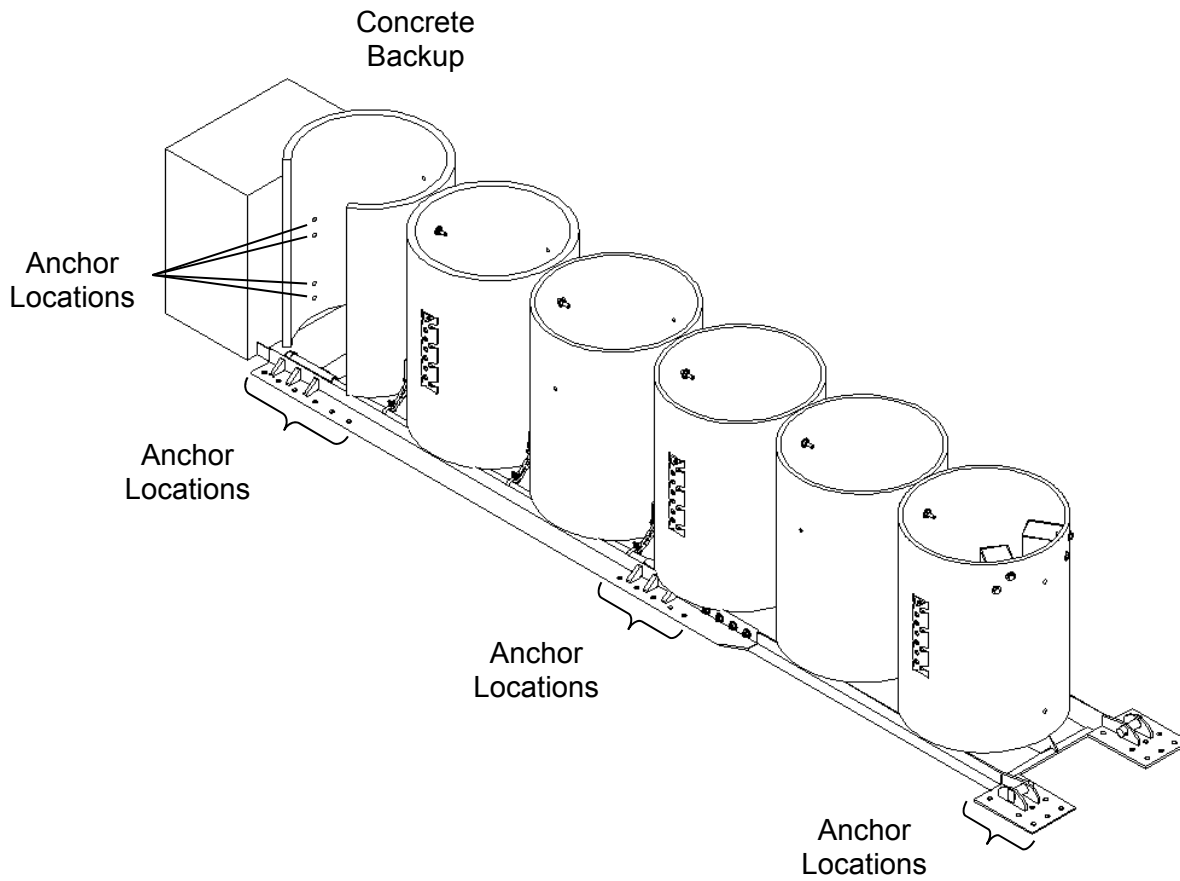

Figure 18 - Anchoring the System - Concrete Backup

3) Drill and Set Side Anchor Plate Anchors



Warning: For REACT 350[®] II system with a Concrete Backup, Side Cable Anchor Plates must be attached.



Warning: The vertical placement of the Side Anchor Plates is critical to the performance of the REACT 350[®] II system. If an existing backup is not tall enough to fulfill these requirements, special brackets are available. Consult Energy Absorption Systems Customer Service for further information.

When correctly assembled, the top of the Side Cable Anchor Plates should be 991 mm (39") from the road surface. The front edge of the Side Cable Anchor Plates should be 51 mm - 102 mm [2" - 4"] from the front face of the backup to avoid reinforcing steel. The tapered side of the Side Cable Anchor Plates should face the front of the System (see Figure 19). Use the holes in the Side Cable Anchor Plates as templates to match drill ten holes per side of backup, 22 mm [7/8"] diameter x 140 mm [5 1/2"] deep into the Concrete Backup. Use horizontal MP-3[®] kit to place twenty 3/4" diameter x 6 1/2" long studs using instructions included with kit. After grout has hardened, use 3/4" flat washers and nuts provided with kit to attach side cable anchor plates (one on each side) to Concrete Backup as shown in Figure 19.



Warning: Once the grout has hardened, see Table B on Page 36 for hardening times, torque nuts to 165 N-m [120 ft-lb].

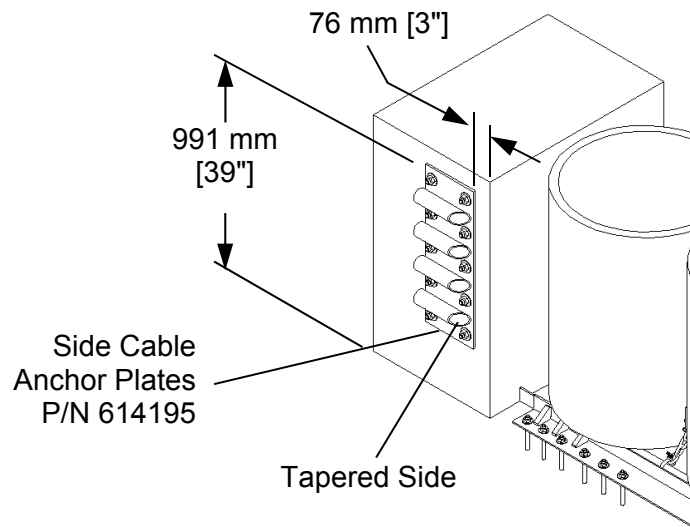

Figure 19 - Side Cable Anchor Plates

4) Attach Restraining Cables



Warning: Four Restraining Cables must be attached; two on each side of backup.

- A. Slide the threaded end of a Restraining Cable through the third guide down and attach flat washer and nut as shown in Figure 20. Tighten the nut so it is flush with the end of the threaded end of cable.

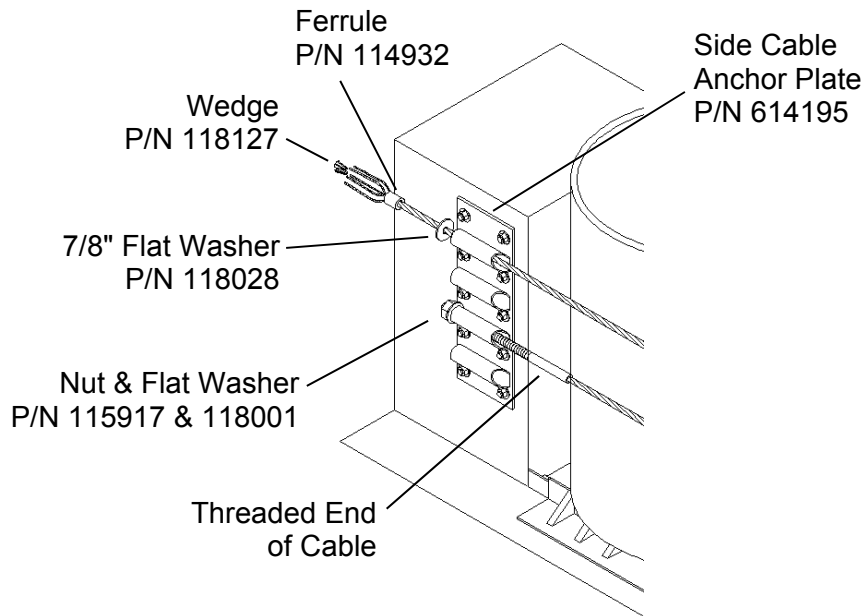

Figure 20 - Routing First Cable

- B. Route the Restraining Cable through the Cable Guides on the sides of the Cylinders, around the Restraining Cable Pin as shown in Figure 21, back through the Top Cable Guides on the Cylinders and through the Top Cable Guide of the Side Plate (See Figure 22).

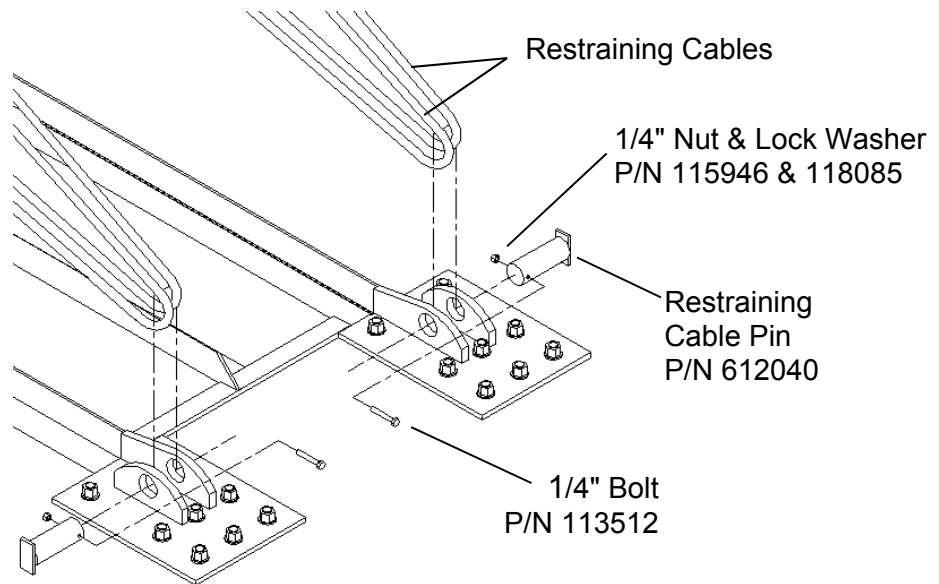
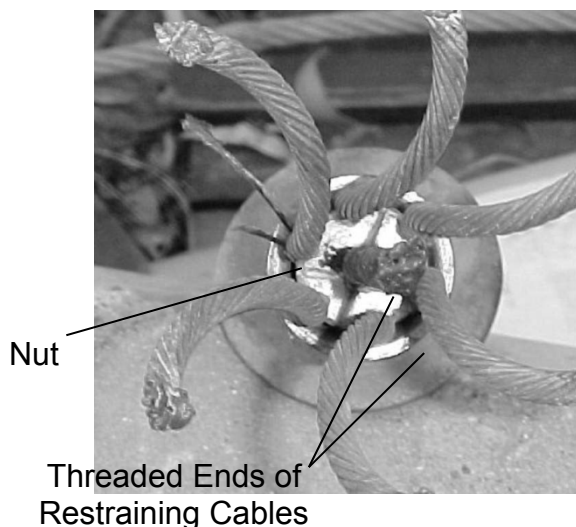

Figure 21 -Front of System Cable Attachment (Concrete Backup)

3. Pull on the cut end of the cable removing all possible slack. Slide the 7/8" x 3" flat washer and the ferrule (in that order) over the end of the non-threaded end of the Restraining Cable. Mark the cable 50 mm [2"] back from the ferrule. Leaving the ferrule and washer in place, cut the cable at the mark with a grinder or hack saw. Do not use a torch to cut the cable. Unbraid end of cable and insert middle strand between the two halves of the wedge. Carefully wrap the remaining six strands into the two halves of the wedge. Carefully wrap the remaining six strands into the slots around the wedge then push into ferrule to tighten (See Figure 22 and Detail A). Use a drift pin and sledge hammer to seat the ferrule into the cable receptacles.

Repeat these steps for remaining three Restraining Cables ensuring that the threaded ends of the Restraining Cables are attached through the lower two guides as shown in Figure 22.



**Figure 22 – Rear Cable Attachment
Concrete Backup**

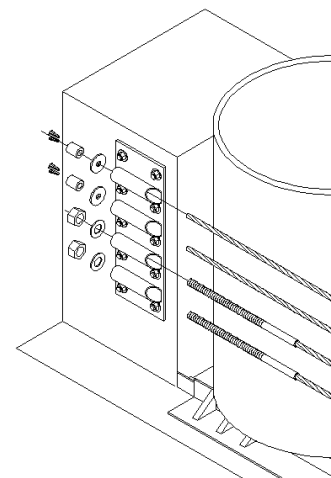

Detail A – Cable Ferrule

5) Tension Restraining Cables

Use the nuts on the threaded end of the cables to tension the cables (See Figure 22).

When properly tensioned, the cables should not deflect more than 75 mm [3"] with 45 kg [100 lb.] downward pressure.

Attach Nose Cover

1. Ensure appropriate Nose Cover is attached (See Figure 23). The Nose Cover Selection below will assist in your selection and you should refer to local standards and "Manual on Uniform Traffic Control Devices" (MUTCD) for nose.

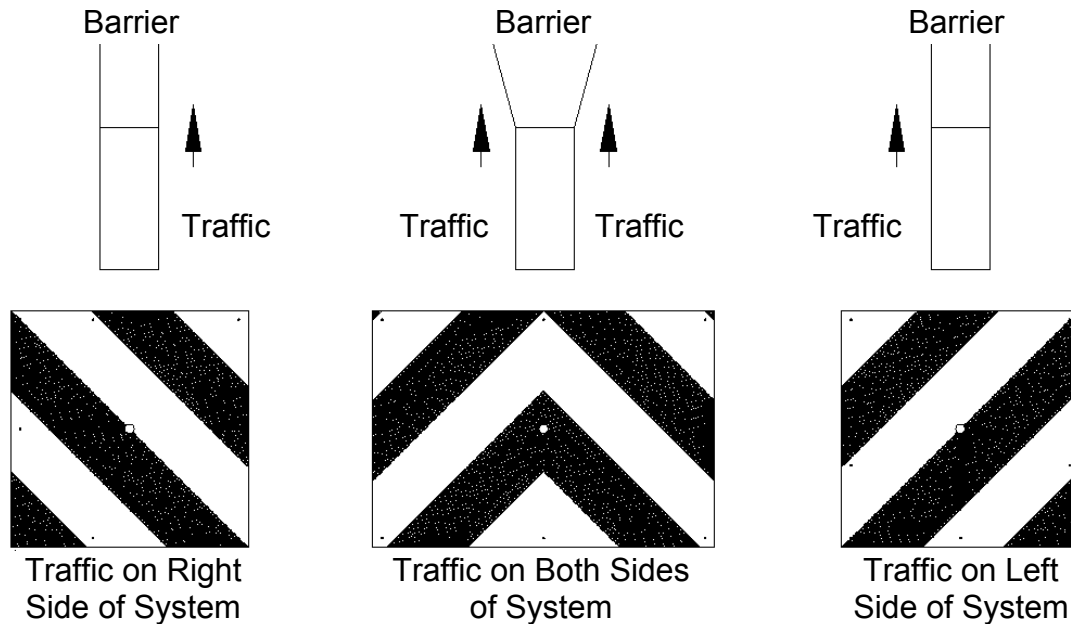

Figure 23 - Nose Cover Selection

2. Align 1" diameter hole in Nose Cover with 1" diameter hole in Cylinder (See Figure 24).
3. Screw 1/4" self-drilling screw into Cylinder punching through reflective tape and into the existing holes in Nose Cover until head of fastener is flush (10 places) (See Detail B).

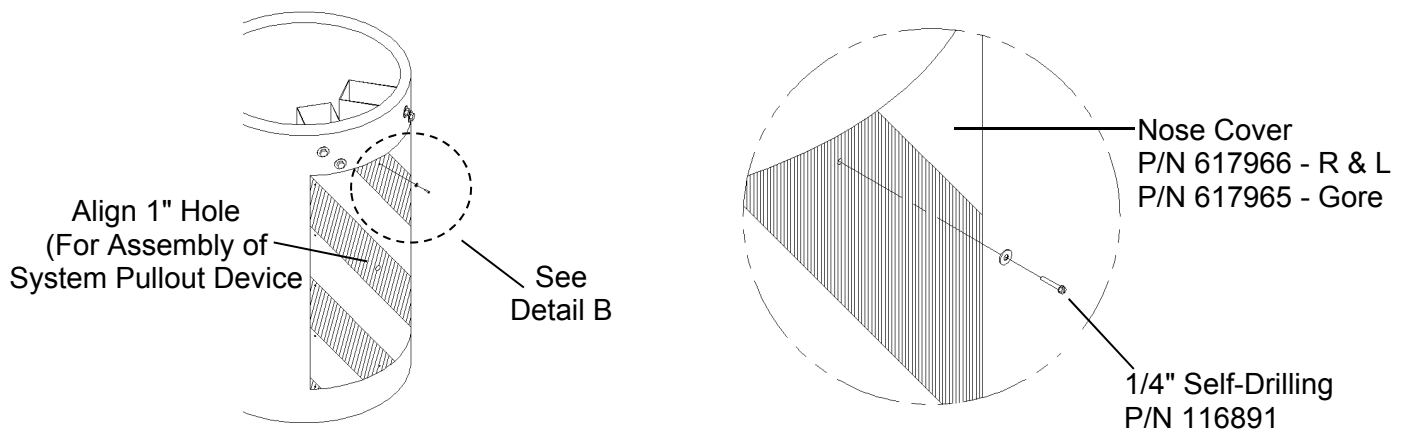

Figure 24 - Nose Cover Attachment

Detail B

Affix Side Mount Reflectors

Refer to local standards and “Manual on Uniform Traffic Control Devices” (MUTCD) for reflectors.

For Side Mount Reflectors, attach to traffic side(s) of the system with the white side facing traffic by screwing #8 self-tapping screws through the reflector and into the Cylinder until head of fastener is flush (2 places per reflector) (See Figure 25).

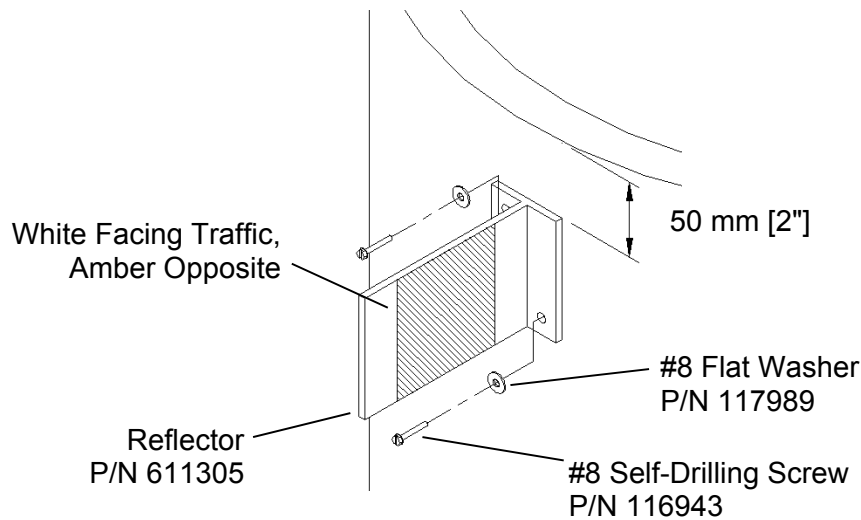

Figure 25 - Side Mounted Reflector

Optional Debris Covers

To attach Optional Debris Covers, center a cover on Cylinder 1. Note the orientation of the grommets. The two grommets closest together should be located in the front or rear of the Cylinder (See Figure 26).

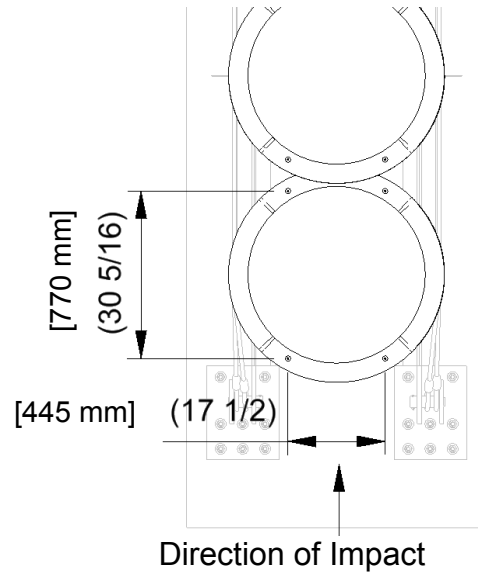

Figure 26

Next attach the four #10 flat head screws and fender washers ensuring the screw is positioned in the middle of the Cylinder wall (See Figure 27).

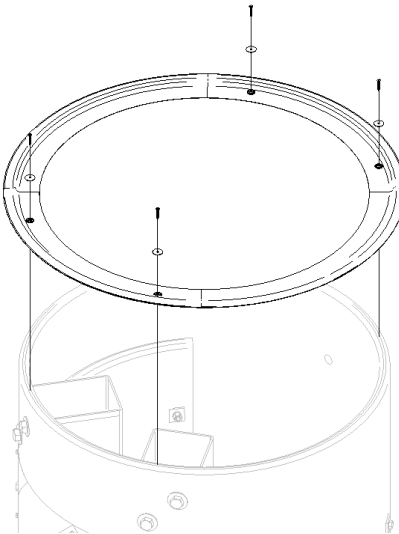

Figure 27

Continue to attach the remaining covers as described above.

Note: The covers may overlap; however, the overlap direction is not critical to system performance.

MP-3[®] Polyester Anchoring System

The MP-3[®] Polyester Anchoring System is a quick and easy way to securely anchor crash cushions and other common highway devices. MP-3[®] features high pullout strength, superior vibration resistance, and exceptional durability.

Each MP-3[®] kit contains a can of MP-3[®] resin, hardener, cold-weather promoter, studs, washers, nuts, and a complete safety sheet. The cold-weather promoter shortens hardening time by as much as seven hours. Both vertical and horizontal assemblies are possible using the MP-3[®] system.



Warning: Read MP-3[®] Instructions before starting.



Warning: Do not allow the MP-3[®] Resin or Hardener to contact skin or eyes. See material safety data sheet supplied with the MP-3[®] kit for first aid procedures. Use only in well-ventilated area. Do not use near open flame.



Warning: Wear safety goggles and gloves during assembly.

Vertical Assemblies

1) Prepare the concrete pad

The anchor bolts (studs) that anchor the REACT 350[®] II System to the concrete pad must be those shipped in the kit or of high strength steel (830 MPa [120,000 psi] minimum tensile strength). These studs must be set in minimum 28 MPa [4000 psi] concrete. Allow the concrete to cure a minimum of seven days before applying MP-3[®].

2) Drill holes

Note: Energy Absorption Systems recommends using double fluted drill bits to achieve optimum tensile strength when assembling the MP-3[®] anchoring system. That decision must be confirmed with the highway authority authorizing the assembly and that it is assembled to their specification.

Use the part that is to be anchored as a drilling template. Drill the holes 3 mm [1/8"] larger than the stud diameter to the recommended depth with a rotary hammer drill. Full strength will not be achieved if a diamond bit is used. Refer to the MP-3[®] Assembly instructions provided with your kit. Check to be sure all the holes are drilled to the proper depth and aligned with the part to be anchored (See Table A).

Table A: MP-3[®] Polyester Anchoring Information			
3/4" Ø Stud Length	Concrete Bit Size	Minimum Depth	Recommended Torque
6 1/2"	22 mm [7/8"]	125 mm [5"]	165 N-m [120 ft-lb]
7" 7 1/2" 8 1/2"	22 mm [7/8"]	140 mm [5 1/2"]	165 N-m [120 ft-lb]
18"	22 mm [7/8"]	420 mm [16 1/2"]	<15 N-m [<10 ft-lb]

3) Clean the holes

Blow the concrete dust from the hole, using oil-free compressed air. Thoroughly brush it with a stiff-bristled brush, and then blow it out again. If the hole is wet, completely flush it with water while brushing, then blow it clean, using oil-free compressed air.

4) Mix the resin and hardener

Wearing gloves and safety goggles, remove the lids from the MP-3[®] Part A-Resin and Part B-Hardener containers. Pour Part B into Part A, then mix vigorously for 30 seconds to form MP-3[®] grout (an anchor stud may serve as a stirring rod).

5) Add cold-weather promoter (in cold weather)

For faster hardening in cold weather, cold-weather promoter may be used. Add the entire contents of the partially filled cold-weather promoter container to the MP-3[®] grout, then mix for an additional 30 seconds. Use immediately because the MP-3[®] grout will thicken quickly. Refer to Table B on Page 36 for hardening times.



Warning: Do not use MP-3[®] cold-weather promoter when the temperature is above 15 degrees Celsius (60 degrees Fahrenheit). Grout will harden too quickly.

6) Pour grout into holes

Crimp the mouth of the can to form a spout and pour the MP-3[®] grout mixture down into the hole through the part. Fill the hole 1/3 to 1/2 full.



Warning: Do not overfill or under fill the hole. If the hole is overfilled, there will not be enough grout to use all of the anchor studs per kit. If hole is under filled the grout may not develop the required pull-out strength.

7) Add the washers and nuts

Place a flat washer onto the stud; then thread a nut on until **1 or 2 threads of the NUT** are left exposed (See Figure 28).

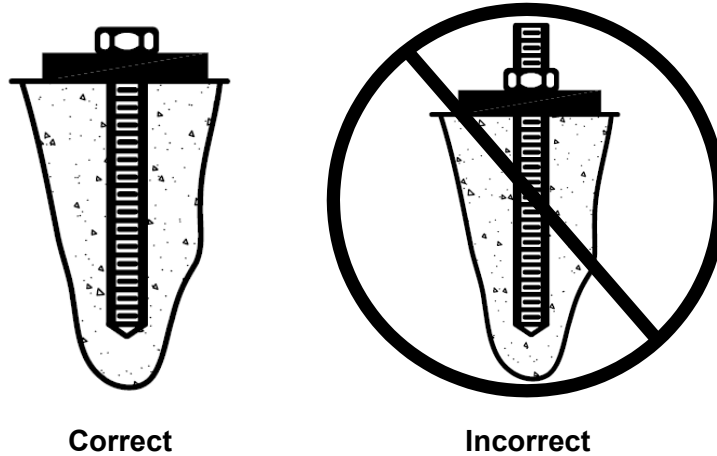

Figure 28 - MP-3® Vertical Assembly

8) Insert Studs in holes and wait for grout to harden

Push the stud down through the part to be anchored and into the hole. Give the stud several twists in the MP-3® to wet the threads.



Warning: Do not disturb or load the stud until the MP-3® material has hardened (See Table B).

Table B: Approximate Hardening Times			
Temperature		No Promoter	With Promoter
(C)	(F)	(time in hours)	
>26	>80	1/2	N/R*
22-26	70-79	1	N/R*
16-21	60-69	2	N/R*
10-15	50-59	4	3/4
4-9	40-49	8	1
-1 -3	30-39	N/R*	1 1/2
<-1	<30	N/R*	N/R*

9) Torque the nuts

Once the grout has hardened, torque the nut to the recommended values above.

Horizontal Assemblies

The Horizontal MP-3[®] kit is the same as the vertical kit except that a cartridge for a standard caulking gun is supplied in the horizontal kits and the resin for the horizontal kits is a Thixotropic (TX) Resin. The TX-Resin is a gelled resin designed to keep the grout in place in horizontal holes during assembly.

When using the Horizontal MP-3[®] kits, follow the vertical instructions with the following exceptions:

1) Thread dispensing tip onto dispenser

Prior to mixing the grout, carefully thread the dispensing tip onto the dispenser.

2) Pour mixed grout into dispenser

Once the grout is mixed, crimp the mouth of the can to form a spout and pour the MP-3[®] grout into the open end of the dispenser (use mixing stud to scrape out the portion remaining in the can). You may use the box to hold the dispenser upright. Close the box lid and poke the dispenser tip into the top of it. Seal the dispenser with the plunger provided.

3) Place dispenser in caulking gun and dispense grout

Cut off the small end of the dispenser tip. Place the dispenser into a caulking gun and dispense until MP-3[®] TX grout reaches the tip of the dispenser, then release pressure. Push the dispenser tip through the part to the bottom of the hole and dispense while slowly withdrawing the tip. Fill the hole 1/3 to 1/2 full.



Warning: Do not overfill or under fill the hole. If the hole is overfilled, there will not be enough grout to use all of the anchor studs per kit. If hole is under filled the grout may not develop the required pull out strength.

4) Add the washers and nuts

Put washer and nut on stud leaving nut flush with end of stud (See Figure 29).

5) Insert Studs into holes

Push stud through part to be anchored and into hole. Give the stud several twists in the MP-3[®] grout to wet the studs.

Note: In Horizontal applications the stud should be flush with the top of the nut. Torque to 165 N-m [120 ft-lb] after cured.

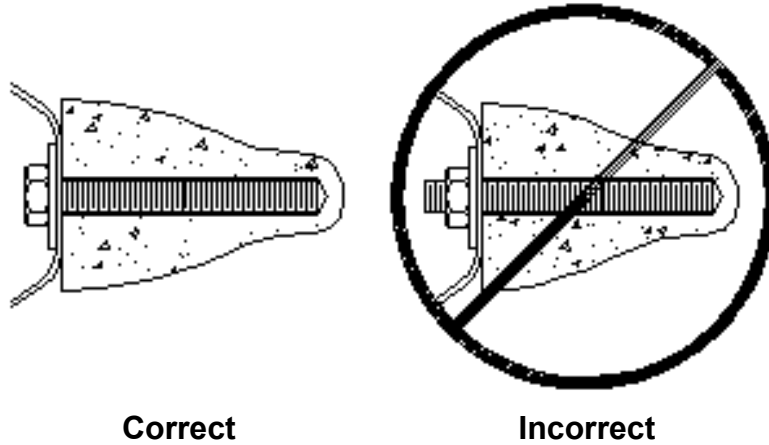

Figure 29 - MP-3® Horizontal Assembly

MP-3® Application Cautions

1) Shelf life

If the shelf life of the MP-3® has expired (see MP-3® kit for expiration information), mix a small amount of MP-3® in the proportions of one part A to two parts B by volume. If the material does not set according to the instructions, contact Energy Absorption Systems for guidance.



Warning: Do not use the MP-3® if: the material fails to set up, Part A-Resin has gelled (for vertical applications), or TX-Resin is NOT gelled (for horizontal applications).

2) Steel rebar

If steel rebar is encountered while drilling an MP-3® anchor bolt hole, apply one of the following solutions:

- A. Using a diamond core drill bit or rebar drilling tool, drill through the rebar only, then switch back to the concrete bit and drill into the underlying concrete until the proper hole depth is reached.



Warning: Do not drill through rebar without first obtaining permission to do so from the local project engineer.

- B. Drill a new hole down at an angle past the rebar to the proper depth. Anchor the stud by completely filling both holes with MP-3®.

Maintenance and Repair

The REACT 350[®] II system, through crash testing, has been shown to be a potentially reusable crash cushion. After those impacts observed within NCHRP 350 criteria, it has been observed that, potentially, the bulk of the system can be reused. However, whether or not a system is reusable is the sole discretion of the highway authority specifying their use.



Warning: After an impact, always follow the “Post-Impact Instructions” on Page 42.

Estimated Time for Maintenance

An experienced two-person crew with the proper tools and spare parts should be able to complete the work in one to three hours depending on the damage done to the system.

Life Expectancy

Environment

It is anticipated, given typical environmental conditions that the plastic cylinders will survive in a highway environment for a period ranging from 5 to 15 years from the date of deployment unless impact damage renders them otherwise. However, the life of a system in each specific application should be determined by the highway authority specifying their use and maintaining the system.

Impacts

Potential life expectancy of the system is also dependent on the impacts. This includes:

1. The number of impacts to the system
2. The severity of the impacts
3. The temperature at the time of the impacts

The REACT 350[®] II system must be inspected after each impact. Depending on the impact, components may get damaged and need replacement. A cylinder requires replacement when the minor axis of the cylinder stays permanently at 460 mm [18"] or less (See Figure 30), or the system does not reach 90% of the original length. It is critical that all cables and anchoring be checked and returned to original assembly conditions. Any parts used in the repair of the system must be original Energy Absorption Systems parts (See Page 3).

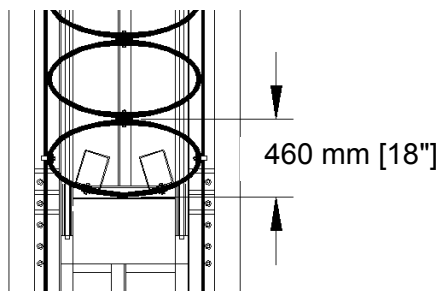

Figure 30 - Measure Minor Axis

Recycling Information

When parts need to be replaced, it is recommended that the old parts be recycled as follows:

Steel should be sold as scrap to a local metal recycler.

HDPE plastic cylinders should be sold to a plastic recycler if available. If a recycler is unavailable, dispose of the material as plastic refuse.

Parts Ordering Procedure

1. Locate the Product Decal attached to the inside of the Rear Cylinder. Copy the sales order information from the decal.
2. Make a list of any damaged parts, using part numbers and descriptions found on the reference drawings included with the REACT 350[®] II system.
3. Only parts specified to be used in this system may be used during repair. The use of a part not specified in this system design renders this system as one that HAS NOT BEEN accepted by FHWA for use on the National Highway System and all observed crash testing to determine system performance is negated. The use of a part not contained herein during the repair renders the systems as something other than that which was crashed and tested accepted by the FHWA for use on the national highway system.

Inspections

Inspections by the appropriate highway authority are recommended as determined by that authority based upon volume of traffic and impact history. Visual drive-by inspections are recommended at least once every three months. Walk-up inspections are recommended at least twice a year.



Warning: After an impact, always follow the “Post-Impact Instructions” on Page 42.

Visual Drive-By Inspection

1. Check to see if there is evidence of an impact. Check to verify that the REACT 350[®] II system is fully extended from the backup. If it is not, a walk-up inspection will be necessary to determine the cause.
2. Note the location and condition of the REACT 350[®] II system and the date of visual drive-by inspection on a log sheet.



Warning: Debris, snow, or ice inside the cylinders may prevent the REACT 350[®] II system from absorbing the impact of a crash as observed in NCHRP 350 compliant crash testing. Perform a walk-up inspection as needed to check for and dispose of any debris inside the Cylinders. Failing to remove this debris or other material infringes upon the performance of the system observed in FHWA accepted crash testing.

Walk-Up Inspection

1. Check for any foreign matter that may interfere with the smooth operation of the REACT 350[®] II system. Check for and remove any debris found inside the Cylinders. Check for and remove any debris found under and around the REACT 350[®] II system.
2. Check for evidence of bent or damaged parts. Replace as soon as possible (See “Parts Ordering Procedure” on Page 40).
3. Verify that all nuts and bolts are tight and rust free.
4. Be sure MP-3[®] Concrete Anchor Bolts are securely anchored.
5. Verify that all Cylinders are in good condition and properly positioned on the Base Track. Any Cylinder that is cracked or otherwise damaged should be replaced. Measure the minor axis of the Cylinders. Cylinders require replacement when the minor axis of the cylinders measures 460 mm [18”] or less (See Figure 30).
6. Ensure all cables are attached with parts specified for use in this system.
7. Note the location and condition of the REACT 350[®] II system and any work done for the date of this inspection. If further repair is necessary, note the repair requested. Refer to the standard drawing and assembly section of this Manual for more information.



Warning: The correct safety equipment and approved traffic management must be used as required for walk-up inspections of the REACT 350[®] II system.

Post-Impact Instructions

1. Deploy the appropriate **traffic control** devices to protect your crew.



Warning: The correct safety equipment and approved traffic management must be used as required for walk-up inspections of the REACT 350® II system.

2. Check to see that all anchor bolts have remained firmly anchored in the roadway surface and in the Concrete Backup, if applicable. Replace any anchors that are loose, broken, or pulled out.
3. Clear and dispose of any debris inside the cylinders and on the site.
4. Check the condition of the Cylinders. Any Cylinder that is cracked or otherwise damaged should be replaced. Measure the minor axis of the Cylinders. Cylinders require replacement when the minor axis of the Cylinders measures 460 mm [18"] or less (See Figure 30).
5. The REACT 350® II system must be pulled out to its original length after each impact. The Pullout Assembly must be attached prior to this procedure and removed and stored when finished (See Figure 31).

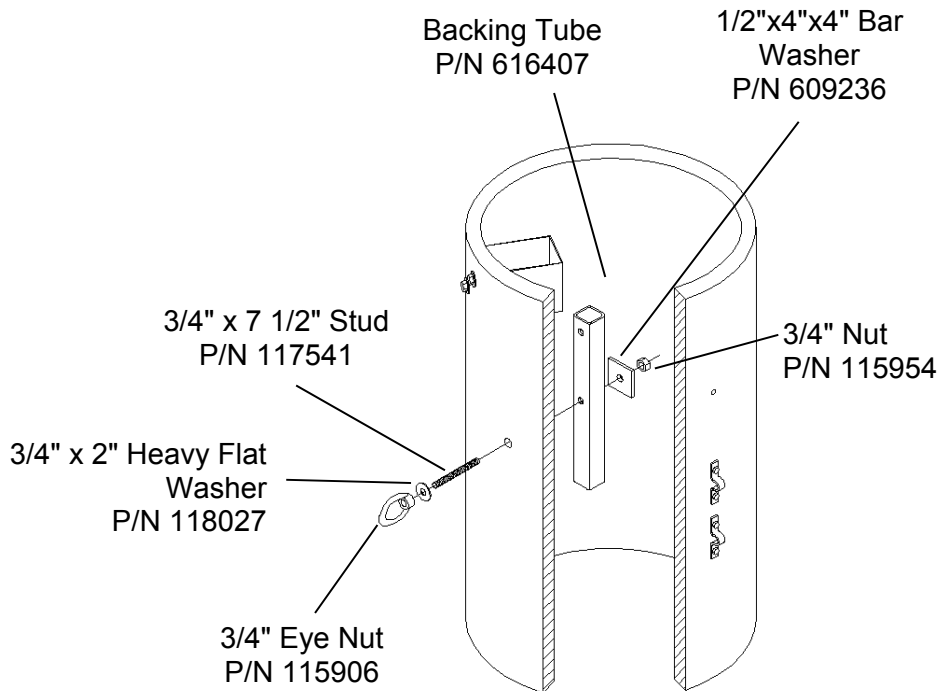
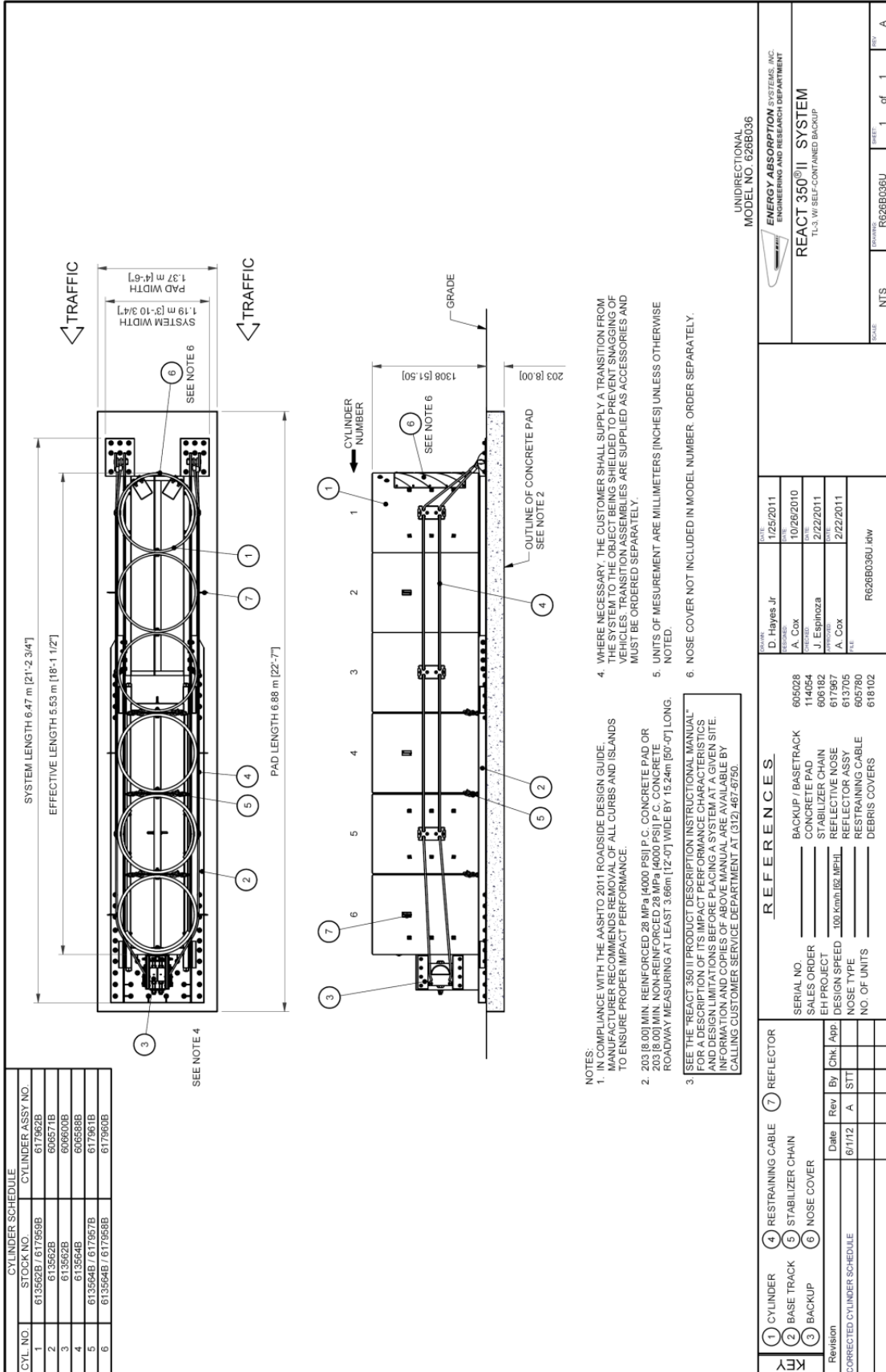

Figure 31 - Pullout Assembly

DWG R626B036U



CYLINDER SCHEDULE	
CYL. NO.	STOCK NO. / CYLINDER ASSY. NO.
1	613562B / 617958B 617962B
2	613562B 606571B
3	613562B 606600B
4	613564B 606598B
5	613564B / 617957B 617951B
6	613564B / 617958B 617960B

SEE NOTE 4

SEE NOTE 6

PAD LENGTH 6.88 m [22'-7"]

SYSTEM LENGTH 6.47 m [21'-2.3/4"]

EFFECTIVE LENGTH 5.53 m [18'-1 1/2"]

PAD WIDTH 1.37 m [4'-6"]

SYSTEM WIDTH 1.19 m [3'-10 3/4"]

GRADE

OUTLINE OF CONCRETE PAD
SEE NOTE 2

203 [8.00]

1308 [51.50]

CYLINDER NUMBER

SEE NOTE 6

SEE NOTE 6

SEE NOTE 6

TRAFFIC

TRAFFIC

NOTES:
1. IN COMPLIANCE WITH THE AASHTO 2011 ROADSIDE DESIGN GUIDE, MANUFACTURER RECOMMENDS REMOVAL OF ALL CURBS AND ISLANDS TO ENSURE PROPER IMPACT PERFORMANCE.
2. 203 [8.00] MIN. REINFORCED 28 MPa [4000 PSI] P.C. CONCRETE PAD OR ROADWAY MEASURING AT LEAST 3.66m [12'-0"] WIDE BY 15.24m [50'-0"] LONG.
3. [SEE THE "REACT 350 II PRODUCT DESCRIPTION INSTRUCTIONAL MANUAL" FOR A DESCRIPTION OF ITS IMPACT PERFORMANCE CHARACTERISTICS AND DESIGN LIMITATIONS BEFORE PLACING A SYSTEM AT A GIVEN SITE. INFORMATION AND COPIES OF ABOVE MANUAL ARE AVAILABLE BY CALLING CUSTOMER SERVICE DEPARTMENT AT (312) 467-6750.]
4. WHERE NECESSARY, THE CUSTOMER SHALL SUPPLY A TRANSITION FROM THE SYSTEM TO THE OBJECT BEING SHIELDED TO PREVENT SNAGGING OF VEHICLES. TRANSITION ASSEMBLIES ARE SUPPLIED AS ACCESSORIES AND MUST BE ORDERED SEPARATELY.
5. UNITS OF MEASUREMENT ARE MILLIMETERS (INCHES) UNLESS OTHERWISE NOTED.
6. NOSE COVER NOT INCLUDED IN MODEL NUMBER. ORDER SEPARATELY.

REFERENCES

REF. NO.	DESCRIPTION	DATE
1	BACKUP / BASE TRACK	1/25/2011
2	CONCRETE PAD	10/26/2010
3	STABILIZER CHAIN	2/22/2011
4	REFLECTIVE NOSE	2/22/2011
5	REFLECTOR ASSY	2/22/2011
6	RESTRAINING CABLE	
7	DEBRIS COVERS	

KEY

KEY	DESCRIPTION
1	CYLINDER
2	BASE TRACK
3	BACKUP
4	RESTRAINING CABLE
5	STABILIZER CHAIN
6	NOSE COVER

Revision	Date	Rev	By	Chk	App
CORRECTED CYLINDER SCHEDULE	6/1/12	A	STT		

DATE	BY	DATE	BY
1/25/2011	D. Hayes Jr	10/26/2010	A. Cox
2/22/2011	J. Espinoza	2/22/2011	A. Cox

MODEL NO.	DATE	BY
UNDIRECTIONAL MODEL NO. 626B036	1/25/2011	D. Hayes Jr

SCALE	NTS	SHEET	OF
		1	1

COMPANY	PROJECT
ENERGY ABSORPTION SYSTEMS, INC. ENGINEERING AND RESEARCH DEPARTMENT	REACT 350 II SYSTEM TL-3, W/ SELF-CONTAINED BACKUP

REACT 350® II TL-3 w/Self-Contained Backup

DWG R626C036U

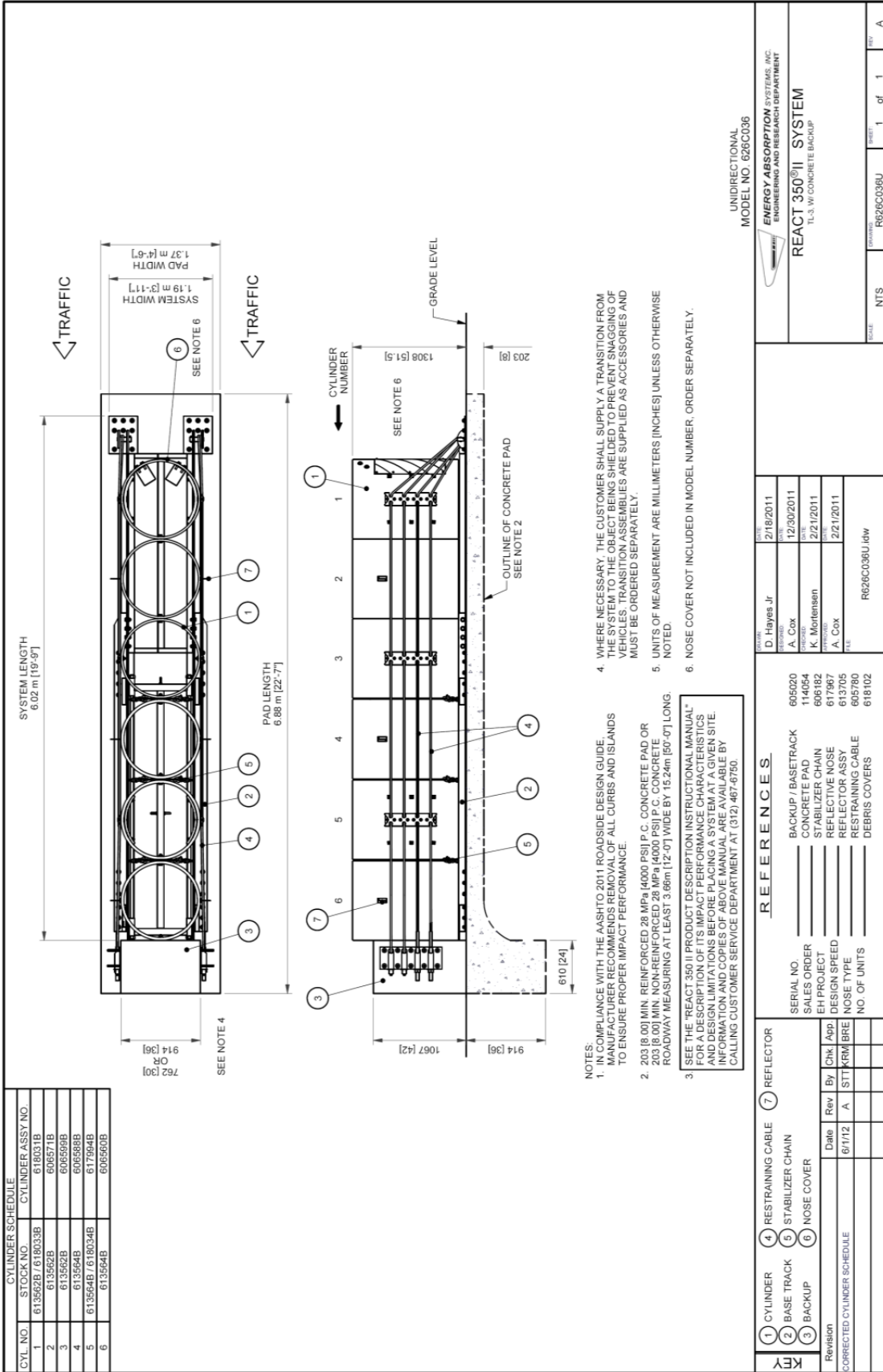

CYLINDER SCHEDULE	
CYL. NO.	STOCK NO. / CYLINDER ASSY NO.
1	613562B / 618033B
2	613562B / 618033B
3	613562B / 606571B
4	613564B / 606598B
5	613564B / 618034B
6	613564B / 617994B
7	613564B / 606560B

KEY	DATE	BY	CHK	APP
1 CYLINDER	6/1/12	A	STT	KRM
2 BASE TRACK				
3 BACKUP				
4 RESTRAINING CABLE				
5 STABILIZER CHAIN				
6 NOSE COVER				
7 REFLECTOR				

REVISION	DATE	BY	CHK	APP
1	6/1/12	A	STT	KRM

NO.	DATE	BY	CHK	APP
1	12/30/2011	A. Cox		
2	2/21/2011	K. Mortensen		
3	2/21/2011	A. Cox		

SCALE	NTS	SHEET	OF	TOTAL
		1	of	1

UNIDIRECTIONAL
MODEL NO. 626C036

ENERGY ABSORPTION SYSTEMS, INC.
ENGINEERING AND RESEARCH DEPARTMENT

REACT 350® II SYSTEM
TL-3, W/ CONCRETE BACKUP

REACT 350® II TL-3 w/Concrete Backup

DWG 3535053-0000

PARTS LIST			
ITEM	STOCK NO.	DESCRIPTION	QTY
1	4720	TRANSITION PLATE ASSEMBLY	2.00
2	2701811-0000	BOLT, RAIL, 5/8X1 1/4, G	16.0
3	2704191-0000	NUT, HX, 5/8, G, RAIL	16.0
4	2752171-0000	END SHOE, W-BEAM	2.00
5	2701641-0000	BOLT, HX, 3/4X1 1/4, G2, G	10.0
6	2704091-0000	NUT, HX, 3/4, G	10.0
7	N/A	W-BEAM PANEL	2.00

NOT SUPPLIED WITH ASSEMBLY SEE NOTES 1 AND 5

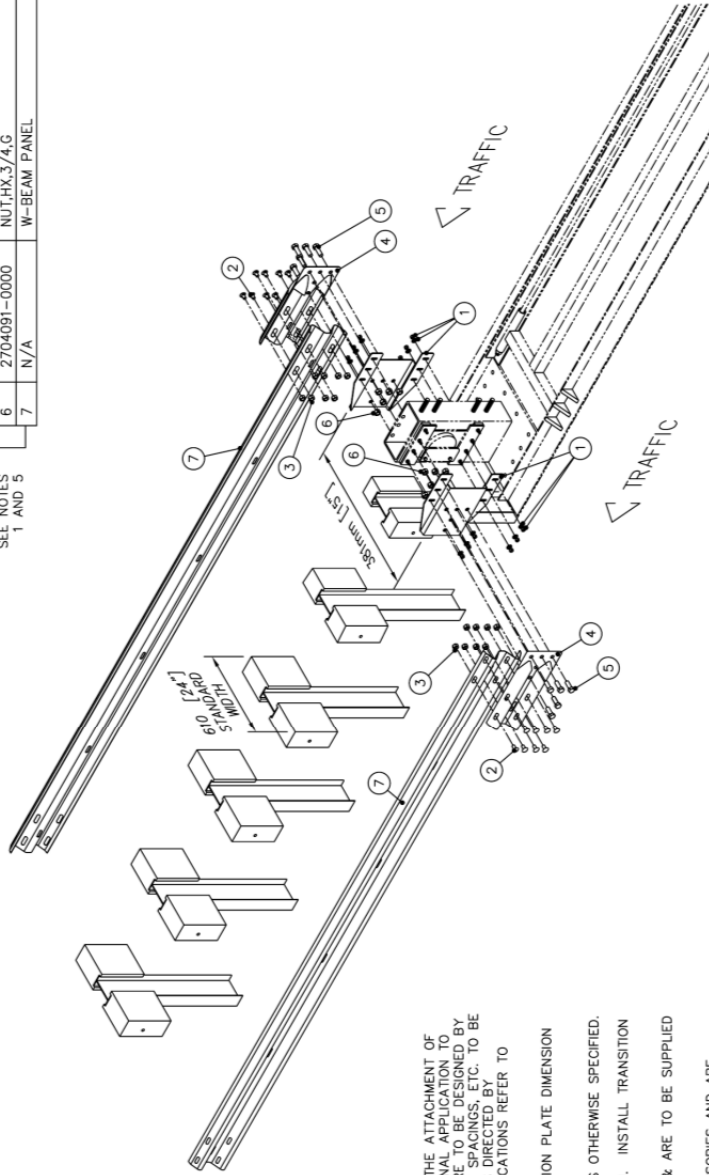

- NOTES:
1. THE SCOPE OF THIS DRAWING IS RESTRICTED TO THE ATTACHMENT OF STANDARD W-BEAM GUARDRAIL IN A UNIDIRECTIONAL APPLICATION TO THE REACT SYSTEM. ALL DOWNSTREAM HARDWARE TO BE DESIGNED BY OTHERS. POST AND BLOCKOUT MATERIALS, POST SPACINGS, ETC. TO BE PER CONTRACT PLANS, STATE STANDARDS OR AS DIRECTED BY RESPONSIBLE AGENCY. FOR BIDIRECTIONAL APPLICATIONS REFER TO DRAWING #3535048-0000.
 2. FACE OF TRANSITION PLATE TO FACE OF TRANSITION PLATE DIMENSION IS APPROXIMATELY 381mm [15"]
 3. DIMENSIONS ARE IN MILLIMETERS [INCHES] UNLESS OTHERWISE SPECIFIED.
 4. EXISTING STUDS, WASHERS, AND NUTS TO REMAIN. INSTALL TRANSITION PLATE ON TOP OF EXISTING HARDWARE.
 5. ITEMS 2-7 ARE STANDARD HIGHWAY HARDWARE & ARE TO BE SUPPLIED BY CUSTOMER.
 6. TRANSITION ASSEMBLIES ARE SUPPLIED AS ACCESSORIES AND ARE ORDERED SEPARATELY.

ASSEMBLY NO. 4720 (ITEM 1) ENERGY ABSORPTION SYSTEMS, INC. ENGINEERING AND RESEARCH DEPARTMENT REACT 350® SYSTEM TRANSITION ASSY, SC BU, UNI, REACT 350		DATE: 1/8/01 CHECKED: KRM APPROVED: B. Burgess DWG NO: 3535053-0000.dwg	SCALE: 1:30 SHEET: 1 of 1
--	--	--	------------------------------

REACT 350® II Transition Assembly, SC BU, UNI

DWG 3535006-0000

ITEM	STOCK NO.	DESCRIPTION	RECD
1	4720	TRANSITION PLATE ASSEMBLY	1.00
2	3525130-0000	ANCHOR,MP-3,PT,KIT,3/4X6 1/2 HOR	1.00
3	2701811-0000	BOLT,RAIL,5/8X1 1/4,G	8.00
4	2704191-0000	NUT,HX,5/8,G,RAIL	8.00
5	2752171-0000	END SHOE,W-BEAM	2.00
6	2701641-0000	BOLT,HX,3/4X1 1/4,G5,G	5.00
7	2704091-0000	NUT,HX,3/4,G	5.00

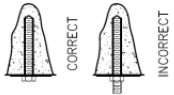

DETAIL B
NOT TO SCALE

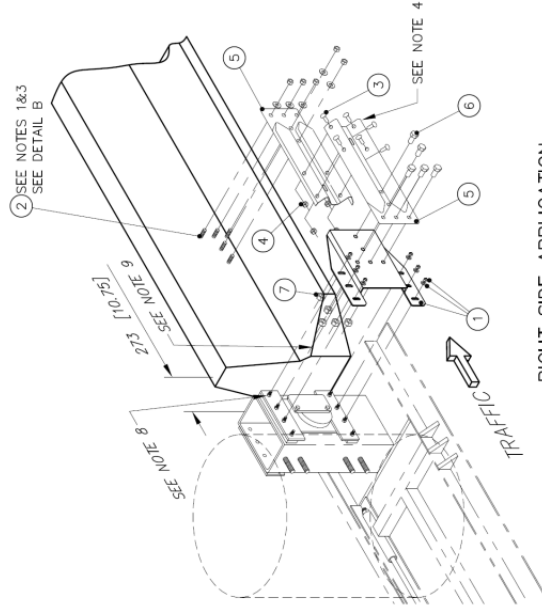

LEFT SIDE APPLICATION

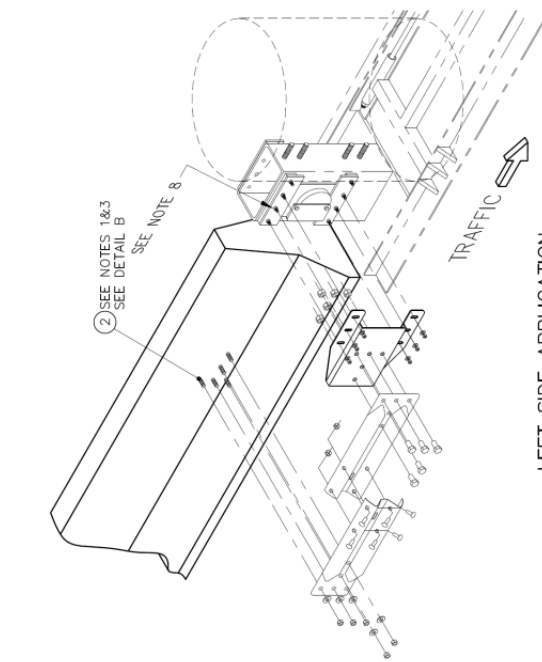

RIGHT SIDE APPLICATION

NOTES:

- USE TRANSITION PANEL AS TEMPLATE FOR DRILLING.
- IMPACT FORCES COULD BE TRANSFERRED INTO TERMINAL END OF THE BARRIER. ADEQUATE REINFORCING AND ANCHORAGE ARE REQUIRED FOR PROPER IMPACT PERFORMANCE.
- ANCHOR STUD END SHOULD BE FLUSH WITH OUTSIDE SURFACE OF ANCHOR NUT, SEE DETAIL B.
- TRANSITION ASSEMBLIES ARE SUPPLIED AS ACCESSORIES AND ARE ORDERED SEPARATELY.
- END SHOES MUST BE LAPPED FOR TRAFFIC DIRECTION.
- ITEMS 3 THROUGH 7 ARE STANDARD HIGHWAY HARDWARE & MAY BE SUPPLIED BY CUSTOMER. ORDER PART NUMBER 4720 TO RECEIVE ITEM 1 ONLY.
- THIS TRANSITION ASSEMBLY MAY BE USED FOR NEW JERSEY BARRIER, F-SHAPED OR VERTICAL CONCRETE WALL.
- EXISTING STUDS, WASHERS AND NUTS TO REMAIN. INSTALL TRANSITION PLATE ON TOP OF EXISTING HARDWARE.
- TRIM BARRIER 5 1/2" DEEP X 14" LONG, AS SHOWN.

Revisions	Date	Rev. By	Chk. App.
ADDED NOTE 8, TRIMMED CMB.	1/17/01	A	DK STT DLJ
ADDED ALL ITEMS AS PART OF ASSY	08/27/02	B	LWC BB SPT
ECO-3371; UPDATED ITEM 6 DESCRIPTION	5/16/12	C	DDW/LME A.C

DATE	9/25/00
DESIGNED	D. Kohfeld
DATE	10/17/00
DRAWN	B. BURGESS
DATE	3535006-0000.dwg
FILE	
SCALE	1:30
PROJECT	3535006-0000
SHEET	1 of 1
REV	C

ASSEMBLY NO. 3535006-0000

ENERGY ABSORPTION SYSTEMS, INC.
ENGINEERING AND RESEARCH DEPARTMENT

REACT 350® SYSTEM

TRANSITION ASSY, SC BU, N, REACT 350

REACT 350® II Transition Assembly, SC BU, N

PARTS LIST			
ITEM	STOCK NO.	DESCRIPTION	REQD
1	4720	TRANSITION PLATE ASSEMBLY	2.00
2	2765046-0000	END SHOE CONNECTOR PLATE	1.00
3	2765044-0000	RUBRAIL BRACE	1.00
4	2701811-0000	BOLT,HX,5/8X1 1/4,G	16.0
5	2704191-0000	NUT,HX,5/8,G,RAIL	24.00
6	2752171-0000	END SHOE,W-BEAM	3.00
7	2701641-0000	BOLT,HX,3/4X1 1/4,G2,G	10.0
8	2704091-0000	NUT,HX,3/4,G	15.00
9	N/A	W-BEAM PANEL	4.00
10	2699341-0000	BOLT,RAIL,5/8X2,G	8.00
11	2708291-0000	WASHER,FLAT,5/8 X 1.3/4,G	8.00
12	2701651-0000	BOLT,HX,3/4X1 1/2,G2,G	5.00

NOT SUPPLIED WITH ASSEMBLY SEE NOTES 1 AND 8

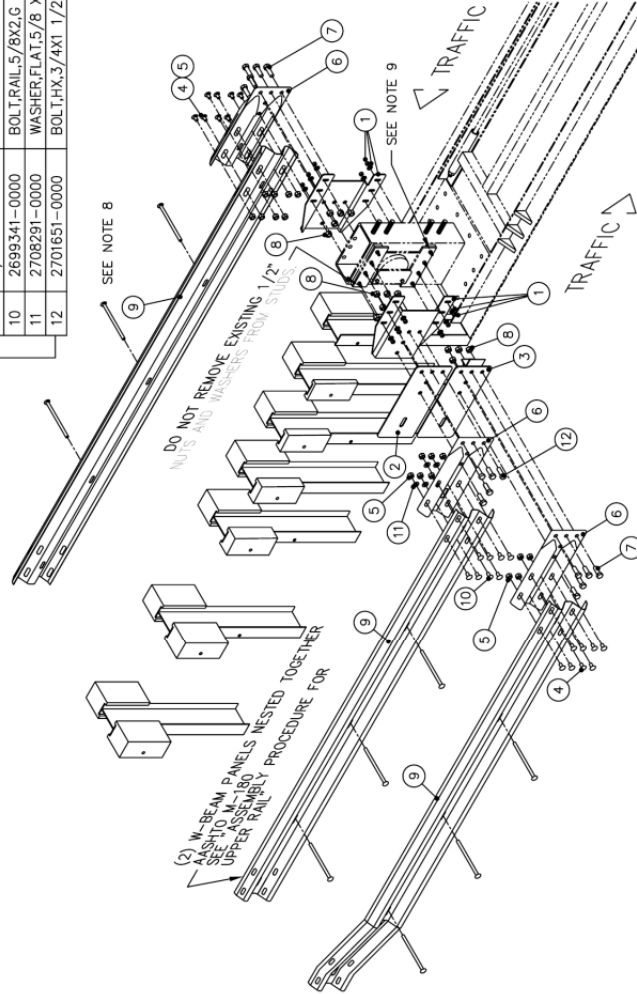

- NOTES:
- STANDARD BARRIER HARDWARE HAS BEEN USED TO DEVELOP THIS GUARDRAIL TRANSITION. SEE "A GUIDE TO STANDARDIZED HIGHWAY BARRIER RAIL HARDWARE," 1995, AASHTO-AGC-ARBTA JOINT COMMITTEE.
 - DO NOT BOLT NESTED W-BEAM OR RUBRAIL W-BEAM TO POSTS AND BLOCKS ON POSTS #2 AND #4. BOLT BLOCKS DIRECTLY TO POSTS.
 - USE OF PLATE WASHERS (FWR01) IS OPTIONAL.
 - THE RUBRAIL MAY BE SHOP BENT IN THE LAST 915mm [36"] TO FACILITATE INSTALLATION.
 - POSTS 1, 3, 5, 6 AND 7 REQUIRE AN ADDITIONAL HOLE TO ATTACH RUBRAIL.
 - TRANSITION ASSEMBLIES ARE SUPPLIED AS ACCESSORIES AND ARE ORDERED SEPARATELY.
 - END SHOES MUST BE LAPPED FOR TRAFFIC DIRECTION.
 - ITEMS 4, THROUGH 12 ARE STANDARD HIGHWAY HARDWARE & ARE TO BE SUPPLIED BY CUSTOMER. RAIL ATTACHMENT, HARDWARE POST AND BLOCKOUT MATERIAL NEEDS TO BE DETERMINED AND SUPPLIED AS NEEDED BY OTHERS. ORDER ASSEMBLY 3535048-0000 TO RECEIVE ITEMS 1, 2 AND 3.
 - DO NOT REMOVE EXISTING STUDS, NUTS, AND WASHERS FROM BACKUP.

DESIGNED BY	D. Kohfeld	DATE	1/23/01
DESIGNED		DATE	
CHECKED BY	KRM	DATE	3/2/01
APPROVED BY	B. Burgess	DATE	3/2/01
CAD FILE	3535048-0000.dwg		

ASSEMBLY NO. 3535048-0000	
ENERGY ABSORPTION SYSTEMS, INC. ENGINEERING AND RESEARCH DEPARTMENT	
REACT 350® SYSTEM	
TRANSITION ASSY, SC BU, N, REACT 350 WITH RUB RAIL	
SCALE	1:30
SHEET	3535048-0000
REF	1 of 3

REACT 350® II Transition Assembly, SC BU, N, w/Rub Rail

DWG 3535048-0000 Sheet 2 of 3

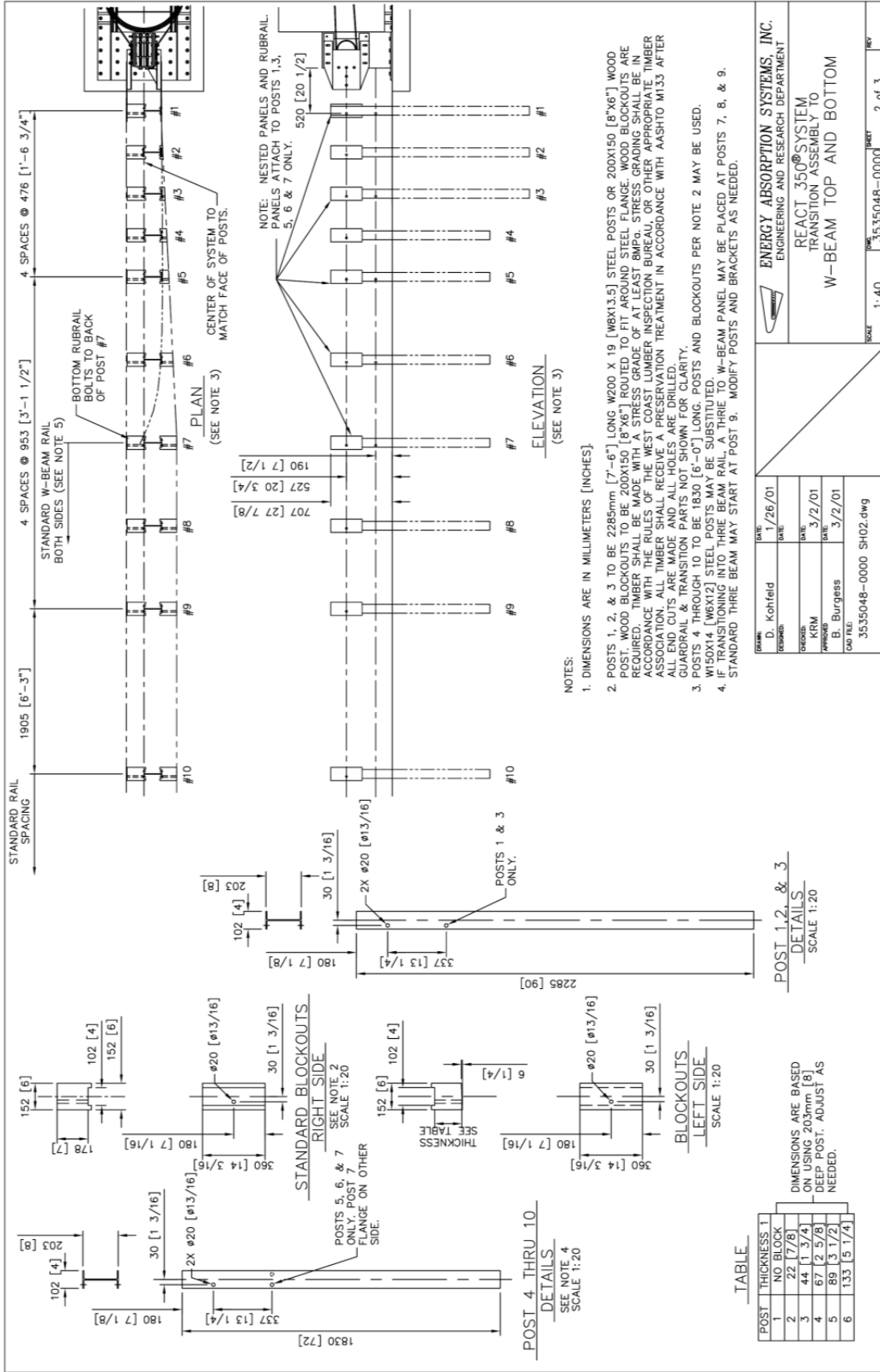

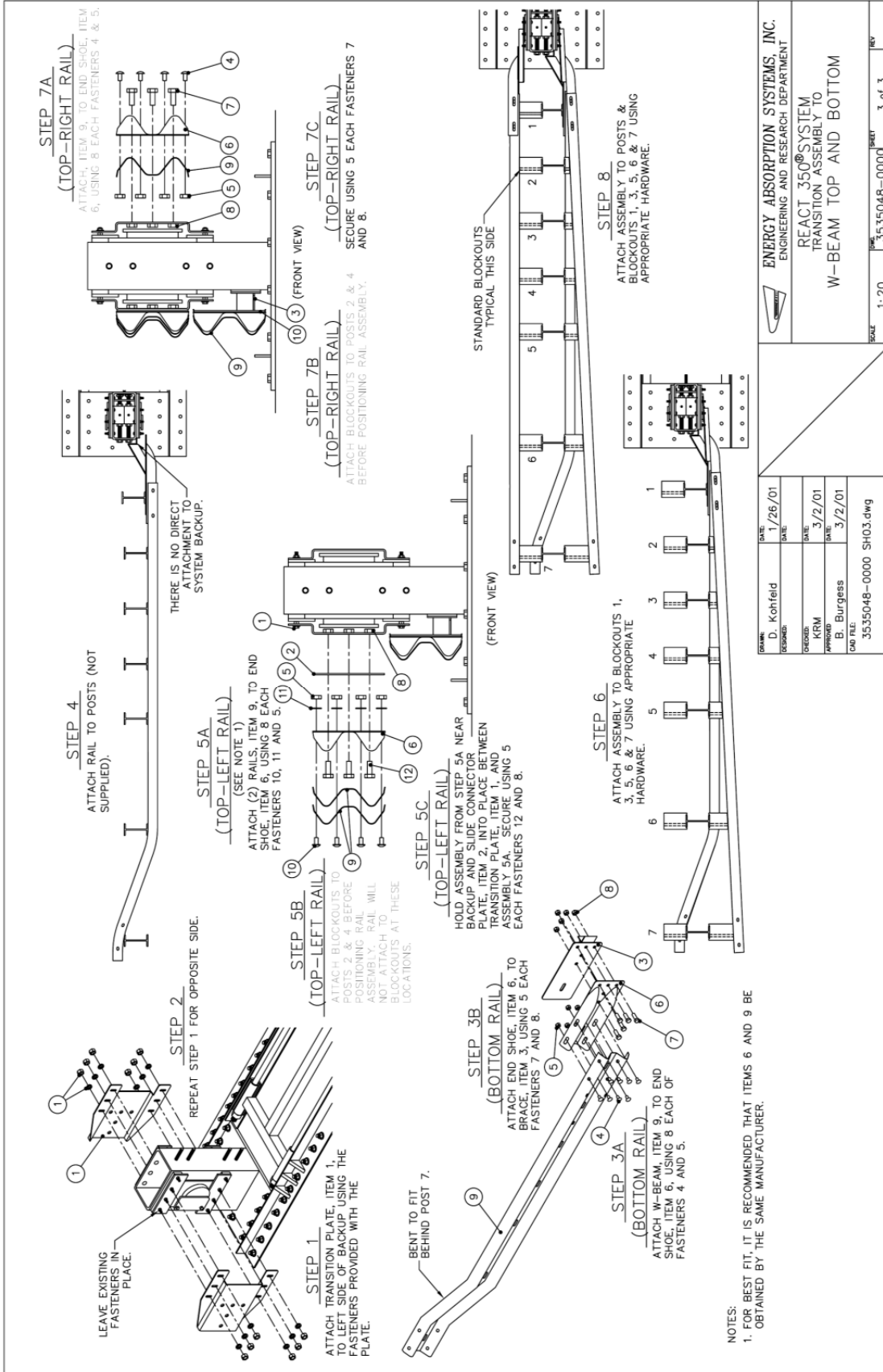

DATE	3/26/01
DESIGNED	D. Kothfeld
CHECKED	KRM
APPROVED	B. Burgess
DWG FILE	3535048-0000 SH03.dwg

ENERGY ABSORPTION SYSTEMS, INC.
ENGINEERING AND RESEARCH DEPARTMENT

REACT 350[®] SYSTEM
TRANSITION ASSEMBLY TO
W-BEAM TOP AND BOTTOM

SCALE: 1:20

DATE	3/26/01
DATE	
DATE	3/2/01
DATE	3/2/01
DATE	

NO.	REV	DATE	DESCRIPTION
3	3 of 3		

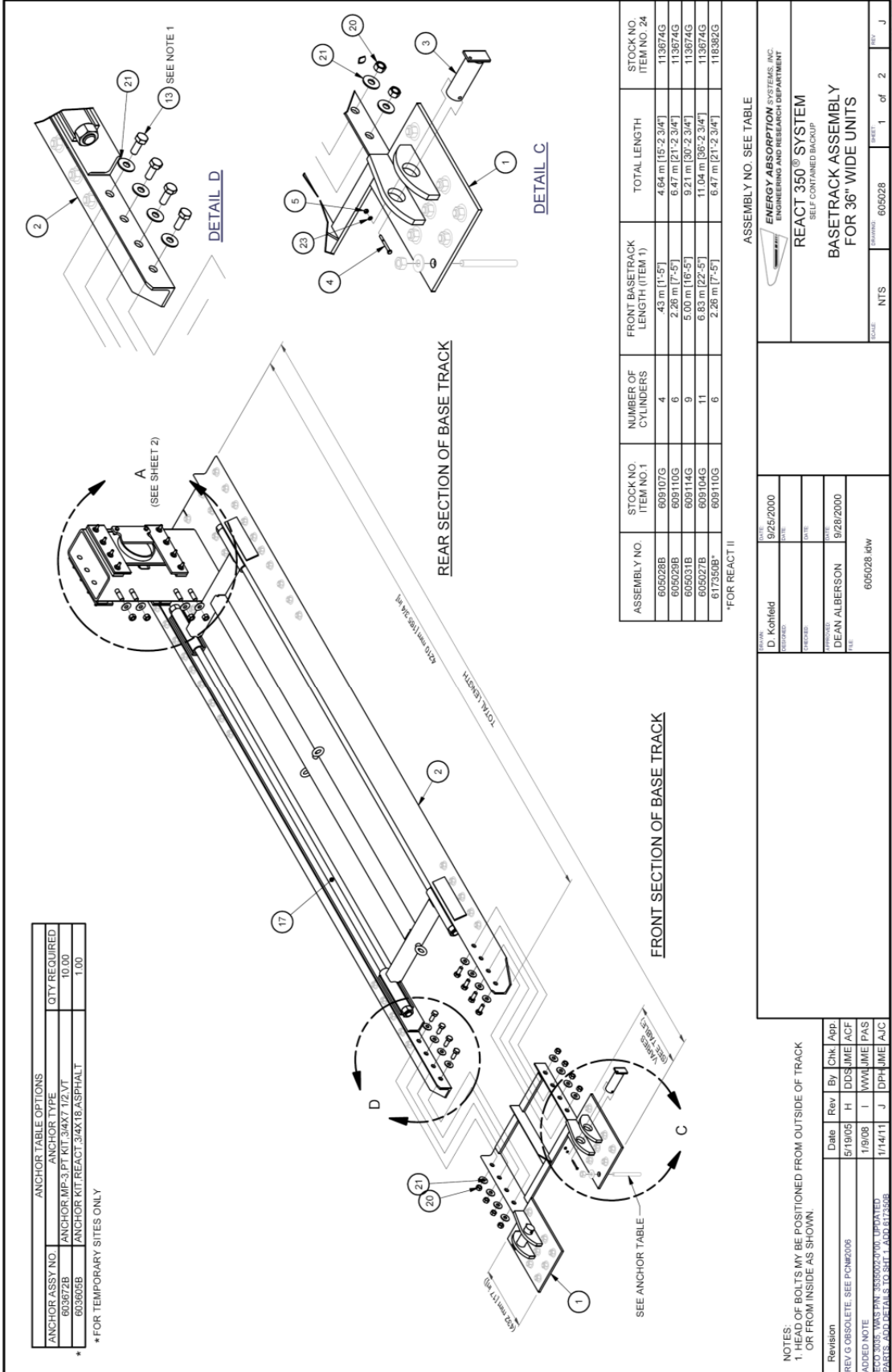

ANCHOR TABLE OPTIONS		
ANCHOR ASSY NO.	ANCHOR TYPE	QTY REQUIRED
603872B	ANCHOR MP-3 PT KIT 3/8X7 1/2 VIT	10.00
603805B	ANCHOR KIT REACT-34X16 ASPHALT	1.00

* FOR TEMPORARY SITES ONLY

ASSEMBLY NO.	STOCK NO. ITEM NO. I	NUMBER OF CYLINDERS	FRONT BASETRACK LENGTH (ITEM I)	TOTAL LENGTH	STOCK NO. ITEM NO. 24
605028B	609107G	4	4.3 m [1'-5"]	4.64 m [15'-2 3/4"]	113874G
605028B	609110G	6	2.26 m [7'-5"]	6.47 m [21'-2 3/4"]	113874G
605031B	609114G	9	5.00 m [16'-5"]	9.21 m [30'-2 3/4"]	113874G
605027B	609104G	11	6.83 m [22'-5"]	11.04 m [36'-2 3/4"]	113874G
6173508*	609110G	6	2.26 m [7'-5"]	6.47 m [21'-2 3/4"]	118382G

*FOR REACT II

ASSEMBLY NO. SEE TABLE

DESIGNED BY D. Kohfeld	DATE 9/25/2000	STOCK NO. 605028	ITEM NO. II
CHECKED BY DEAN ALBERSON	DATE 9/28/2000	SCALE NTS	SHEET 1 of 2
PROJECT REACT 350 [®] SYSTEM SELF CONTAINED BACKUP BASETRACK ASSEMBLY FOR 36" WIDE UNITS		DRAWING NO. 605028.kw	

NOTES:
1. HEAD OF BOLTS MAY BE POSITIONED FROM OUTSIDE OF TRACK OR FROM INSIDE AS SHOWN.

Revision	Date	Rev	By	Chk	App
REV G OBSOLETE. SEE P06R2006	5/19/05	H	DDS	JME	ACF
ADDED NOTE ECCO 3003 - WAS P/N 35350022000. UPDATED PARTS AND DETAILS TO BELL LANE 012358.	1/14/11	J	DPH	JME	AJC

REACT 350[®] II Basetrack Assembly 36" Wide Units

TOP VIEW

SECTION A-A
(SOME HIDDEN LINES NOT SHOWN FOR CLARITY)

DETAIL A
(SOME HIDDEN LINES NOT SHOWN FOR CLARITY)

DETAIL B
(SOME ITEMS NOT SHOWN FOR CLARITY)

NOTES:

- BEFORE INSTALLING CABLE TENSION ROD, W/ NUT, INTO CABLE TENSIONER ASSEMBLY, FILL WITH HEAVY GREASE USING GREASE FILTING. LUBRICATE THREADS ON TENSION ROD.
- ITEM 9 WILL NEED TO BE REMOVED TO INSTALL CABLE (DWG 605786 [3535005-0000]).
- ITEMS 11 & 12 NEED TO BE REMOVED TO INSTALL REAR CYLINDER.
- ANCHORS MUST BE ORDERED SEPARATELY. SEE ANCHOR TABLE OPTIONS SHEET 1.

Revision	Drawn	Rev	By	Chk	App
REV/G OBSOLETE. SEE PCH #2006	5/20/05	H	DDS	JME	ACF
SEE SHEET 1	1/9/08	I	WVN	/	/
#17 WAS 1188236 (2785620-0000), ECO 3035	1/14/10	J	DPH	JME	AJC

DESIGN	D. Kohlsied	DATE	9/25/2000
DESIGNED		DATE	
PACKED		DATE	
APPROVED	DEAN ALBERSON	DATE	9/28/2000
FILE			
605028.dwg			

ASSEMBLY NO. SEE TABLE	
 ENERGY ABSORPTION SYSTEMS, INC. ENGINEERING AND RESEARCH DEPARTMENT	
REACT 350[®] SYSTEM SELF CONTAINED BACKUP BASETRACK ASSEMBLY FOR 36" WIDE UNITS	
SCALE	NTS
TITLING	605028
SHEET	2 of 2
REV	J

ITEM	STOCK NO.	DESCRIPTION	QTY.
1	SEE TABLE	FRONT BASETRACK "G"	1
2	613621B	REAR BASETRACK SCBU(React) G,WIDECAL	1
3	612040G	PIN,RESTRAINING CABLE,G	2
4	113512G	BOLT,HX,1/4X2 1/2,GZ,G	2
5	115946G	NUT,HX,1/4,G	2
6	613734G	RETAINER, TENSIONER,G,(React)	4
7	614628G	STANDOFF,RETAINER,TENSIONER,G,(React)	4
8			
9	605808B	CABLE TENSIONER ASSY,L&R	2
10	113408G	BOLT,GR,1/2X3 1/4,WIRIBBED NECK,G	16
11	115939G	NUT,HX,1/2,G	20
12	113457G	BOLT,HX,1/2X1 1/2,GZ,G	4
13	113552G	BOLT,HX,3/4X2,GZ,G	8
14	115980G	NUT,HX,7/8,G	4
15	118059G	WASHER,FLAT,7/8 X 2 1/4,G	4
16			
17	617946G	RRD ST,1 1/2X130,THREADED,G	2
18	115917G	NUT,HX,1 1/2,G	4
19	118002G	WASHER,FLAT,1 1/4 ID X 2 3/4 OD,G	2
20	115953G	NUT,HX,3/4,G	8
21	118027G	WASHER,FLAT,3/4X2,HVY,G	16
22	118009G	WASHER,FLAT,1/2X1 3/8,G	16
23	118085G	WASHER,LOCK,1/4,G	2
24	SEE TABLE	BOLT,HX,7/8X,GZ,G	4

DWG 605020 Sheet 1 of 3

ANCHOR TABLE OPTIONS		PARTS LIST	
ANCHOR ASSEMBLY NO.	ANCHOR TYPE	ITEM	DESCRIPTION
603672B	ANCHOR_MP-3.PT KIT.3/4X7.1/2.VT	1	BASETRACK FRONT
603670B	ANCHOR_MP-3.PT KIT.3/4X6.1/2.HOR	2	PIN, RESTRAINING CABLE
		3	BOLT, HK, 1/4X2 1/2, G2, G
		4	NUT, HK, 1/4, G
		5	WELDMENT, REAR BASETRACK, CONC.(REACT)
		6	WELDMENT, CABLE ANCHOR, CONC.(REACT)
		8	BOLT, HK, 3/4X2, G2, G
		9	WASHER, FLAT, 3/4X2, HVY, G
		10	NUT, HK, 3/4, G
		11	RRD ST 1 1/2X120, THREADED BOTH ENDS
		12	NUT, HK, 1 1/2, G
		13	STUD, 3/4X8 1/2, G5, G
		14	MP-3, PRINT PACKAGE
		15	WASHER, LOCK, 1/4, G

- NOTES:
- BACKUP MUST BE ABLE TO WITHSTAND A MAXIMUM OVERTURNING MOMENT OF 226 kNm [2000 KIP-IN.] AT DECK LINE FOR DURATIONS 40+ ms.
 - IMPACT FORCES SHOULD BE TRANSFERRED INTO STRUCTURE THROUGH SYSTEM. ADEQUATE ANCHORAGE IS REQUIRED FOR PROPER IMPACT PERFORMANCE.
 - USE ITEMS 1, 5 AND 6 AS TEMPLATES FOR DRILLING CONCRETE. INSTALL ITEM 13 USING MP-3 EPOXY ITEM 14 TO SECURE. USE NUTS AND WASHERS ITEMS 9 & 10.
 - ANCHOR STUD END SHOULD BE FLUSH WITH OUTSIDE SURFACE OF ANCHOR NUT. SEE DETAIL B SHEET 2.
 - UNITS ARE mm [INCHES] UNLESS OTHERWISE NOTED.
 - ANCHOR BOLTS MUST BE ORDERED SEPARATELY. SEE ANCHOR TABLE OPTIONS FOR PART NO.'S & QUANTITIES.

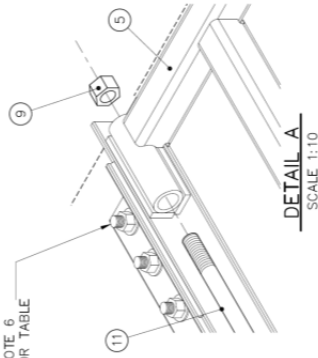
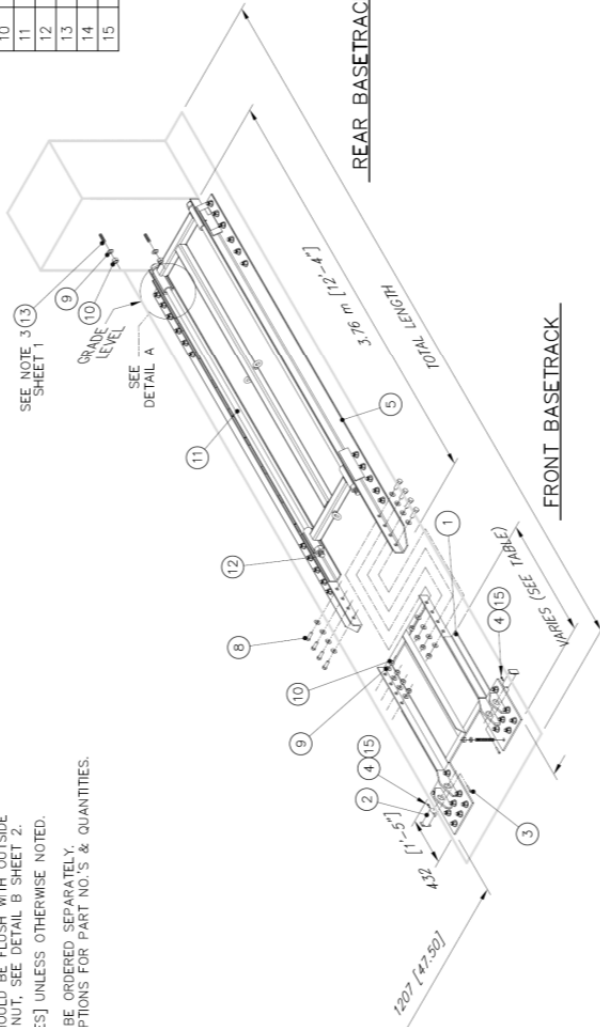

TABLE

BASETRACK ASSEMBLY NO.	STOCK NO. ITEM NO.1	NUMBER OF CYLINDERS	FRONT BASETRACK LENGTH (ITEM 1)	TOTAL LENGTH
605020B	609107G	4	0.43 m [1'-5"]	5.06 m [16'-7"]
605022B	609110G	6	2.26 m [7'-5"]	6.88 m [22'-7"]
605025B	609114G	9	5.00 m [16'-5"]	9.63 m [31'-7"]
605019B	609104G	11	6.83 m [22'-5"]	10.59 m [34'-9"]

Revisions	Date	Rev.	By	Chd.	App.
PCN 1977, UPDATE ITEM 5	03/24/06	E	RCK	KRM	ACF
REV E OBSOLETE. SEE PCN #2006	5/20/05	F	DDJ	JME	ACF
WAS EASI P/N: 3535015-0000	2/17/11	-	JDPH	/	/

DATE	BY	APPROVAL	DATE	BY	APPROVAL
12/22/99	L. CORKER	DEAN ALBERSON	09/28/00	DEAN ALBERSON	DEAN ALBERSON

ASSEMBLY NO. SEE TABLE
ENERGY ABSORPTION SYSTEMS, INC. ENGINEERING AND RESEARCH DEPARTMENT
REACT 350 [®] SYSTEM CONCRETE BACKUP BASETRACK ASSEMBLY 36" WIDE SYSTEMS
SCALE: 1:40
FIG. NO.: 605020
SHEET: 1 of 3
REV. F

REACT 350[®] II Concrete B-up Basetrack Assembly 36" Wide Units

DWG 605020 Sheet 2 of 3

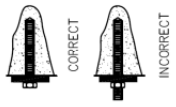

DETAIL B
NOT TO SCALE
SEE NOTE 6 SHEET 1

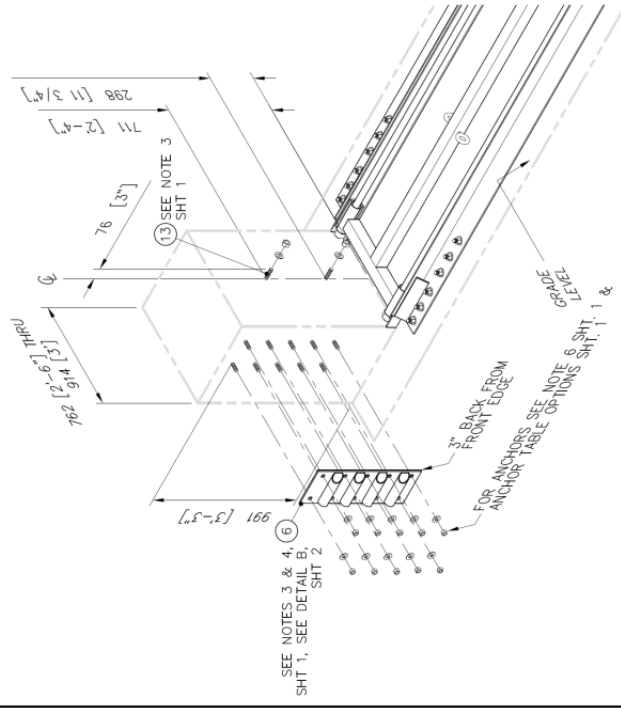

LEFT SIDE VIEW

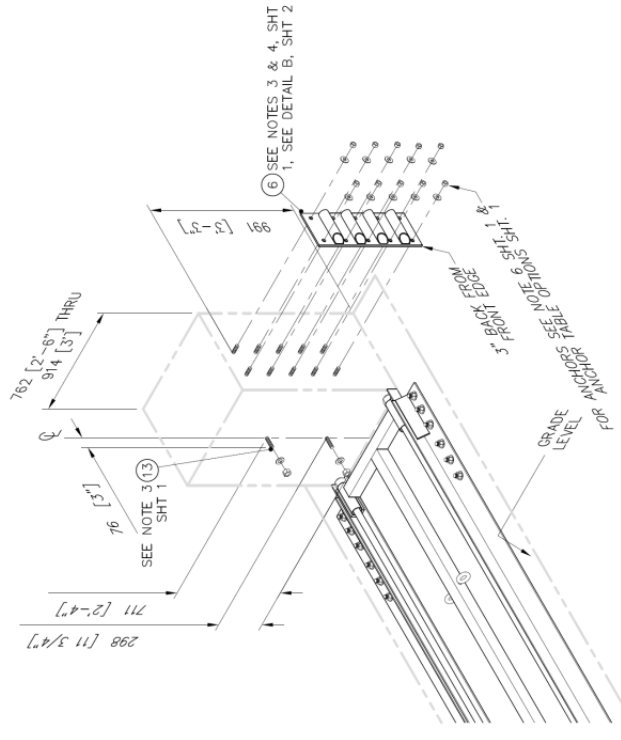

RIGHT SIDE VIEW

DATE: 12/22/99		ASSEMBLY NO. SEE SHEET 1	
DESIGN: L. CORKER	DATE:	ENERGY ABSORPTION SYSTEMS, INC. ENGINEERING AND RESEARCH DEPARTMENT	
REVISION:	DATE:	REACT 350 SYSTEM CONCRETE BACKUP, BASE TRACK ASSEMBLY 36" WIDE SYSTEMS	
CHECKED:	DATE:	SCALE: 1:30	SHEET: 2 of 3
APPROVED: DEAN ALBERSON	DATE: 09/28/00	PROJECT: 605020	REV: F
DWG FILE: 605020			

Revisions	Date	Rev.	By	Chd.	App.
PCN 1977, SEE SHEET 1	03/25/06	E	JRC/KRM	ACF	
REV E OBSOLETE, SEE PCN #2006	5/20/05	F	DDJ/LME	ACF	
WAS EASI P/N: 3535015-0000	2/17/11	-	DPH	/	/

DWG 605020 Sheet 3 of 3

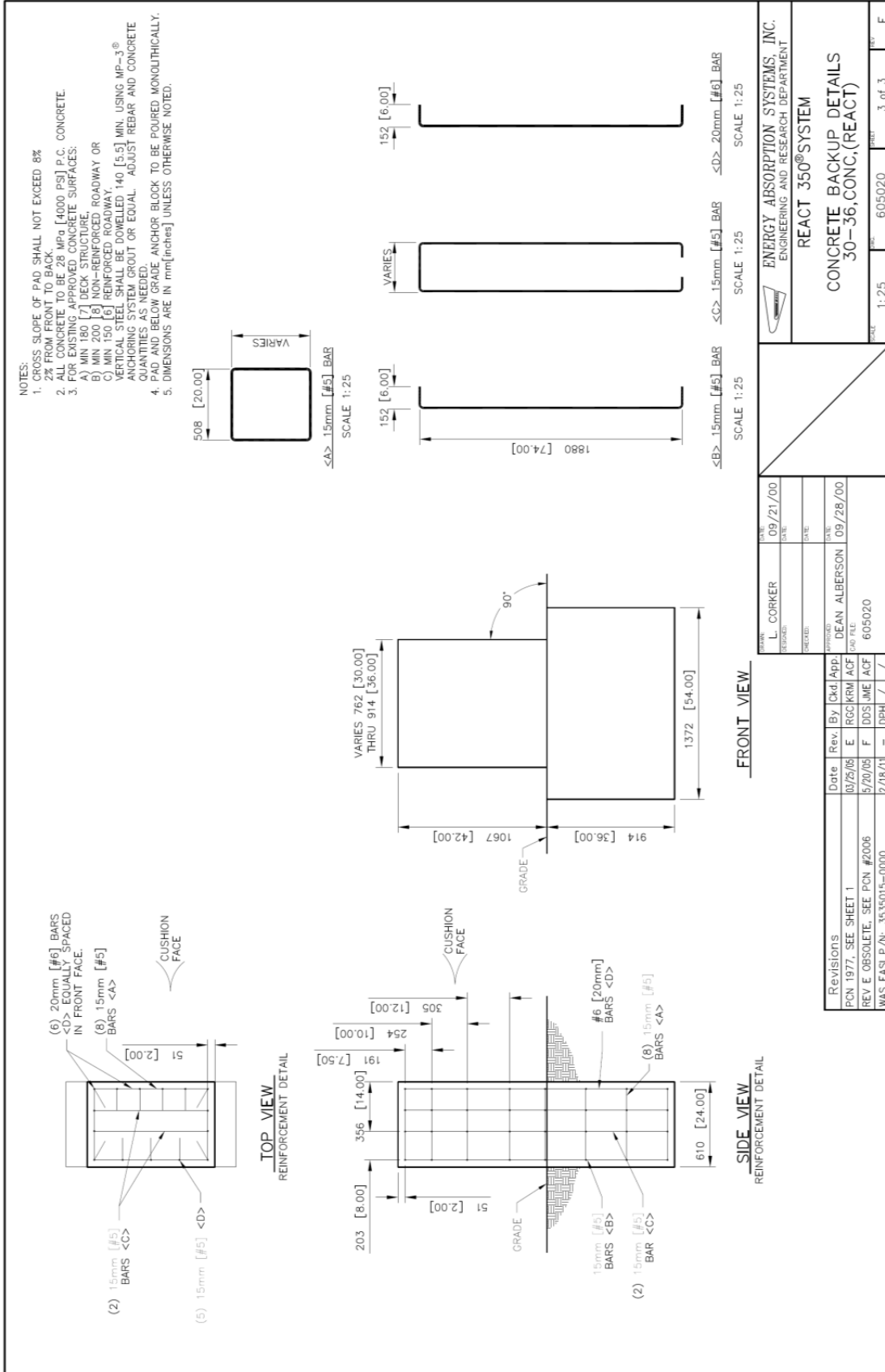

DWG 616084

NEXT ASSEMBLY: MATERIAL:	TOL. ANGULAR: TOL. LINEAR: UNLESS OTHERWISE NOTED:	PARTS LIST <table border="1" style="width: 100%; border-collapse: collapse;"> <tr> <th>ITEM</th> <th>STOCK NO.</th> <th>DESCRIPTION</th> <th>RECD</th> </tr> <tr> <td>1</td> <td>614195G</td> <td>WELDMENT,CABLE ANCHOR,CONC.(REACT)</td> <td>1.00</td> </tr> <tr> <td>2</td> <td>603670B</td> <td>ANCHOR,MP-3,PT KIT,3/4X6 1/2 HOR</td> <td>2.00</td> </tr> </table> * EXPANSION ANCHORS OPTIONAL (SUPPLIED BY OTHERS).	ITEM	STOCK NO.	DESCRIPTION	RECD	1	614195G	WELDMENT,CABLE ANCHOR,CONC.(REACT)	1.00	2	603670B	ANCHOR,MP-3,PT KIT,3/4X6 1/2 HOR	2.00
ITEM	STOCK NO.	DESCRIPTION	RECD											
1	614195G	WELDMENT,CABLE ANCHOR,CONC.(REACT)	1.00											
2	603670B	ANCHOR,MP-3,PT KIT,3/4X6 1/2 HOR	2.00											



CORRECT



INCORRECT

DETAIL B
NOT TO SCALE

SEE NOTES 1 & 3
SEE DETAIL B

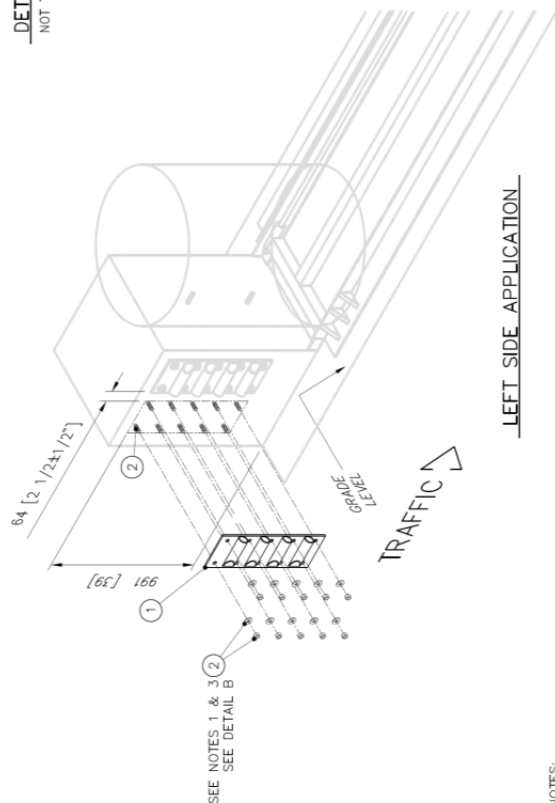

LEFT SIDE APPLICATION

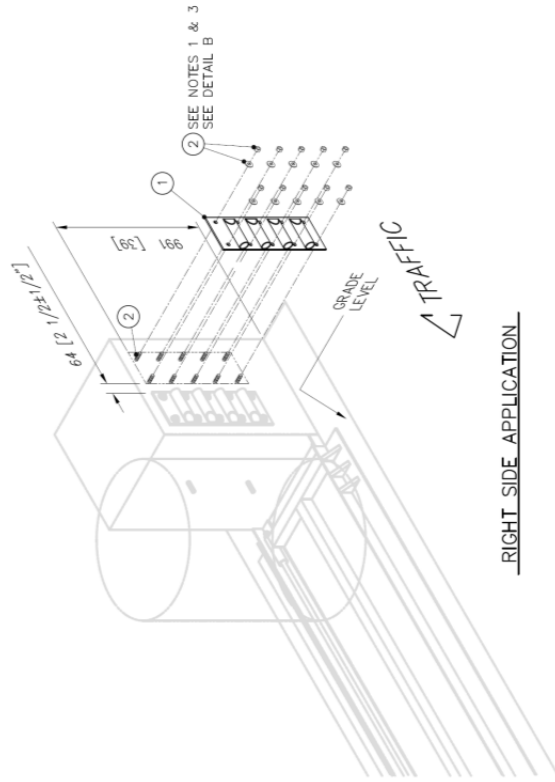

RIGHT SIDE APPLICATION

NOTES:

- USE CABLE ANCHOR (ITEM 1) AS TEMPLATE. FOR DRILLING, RECOMMENDED HOLE DEPTH 140 [5'-1/2"] FINAL TORQUE TO BE 165Nm [120 FT-LBS] (TIP).
- ANCHOR STUD END SHOULD BE FLUSH WITH OUTSIDE SURFACE OF ANCHOR NUT, SEE DETAIL B.
- UNITS ARE mm [INCHES] UNLESS OTHERWISE NOTED.

REACT 350® II Transition Assembly for use w/Concrete Backup

	ASSEMBLY NO. 616084B ENERGY ABSORPTION SYSTEMS, INC. ENGINEERING AND RESEARCH DEPARTMENT
REACT 350® SYSTEM TRANSITION ASSEMBLY FOR USE W/ CONCRETE B.U.	
SCALE: 1:30	SHEET: 616084 1 of 1

DESIGNED BY: L. CORNER	DATE: 01/25/00
CHECKED BY: DEAN ALBERSON	DATE: 09/28/00
APPROVED BY: DEAN ALBERSON	DATE: 09/28/00
DWG FILE: 616084	

Revisions	Date	Rev	By	Chk	App
REVISED B/U & TRANS. ITEM 2 WAS 479	02/09/01	A	RSCG	KM	DLJ
WAS EAST P/N: 3535034-0000	2/15/11	-	DPH	/	/

DWG 114054 Sheet 1 of 2

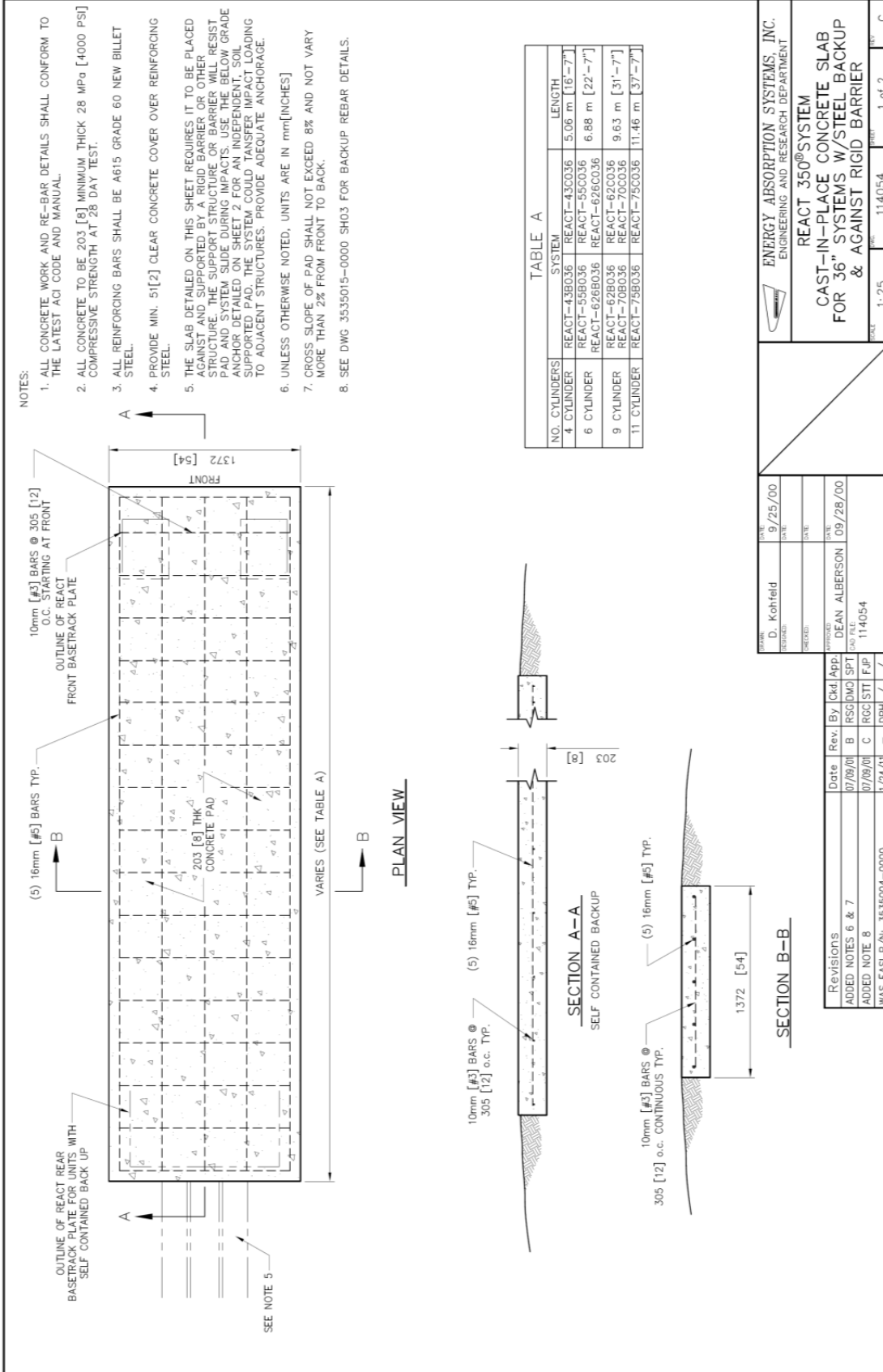

ENERGY ABSORPTION SYSTEMS, INC.
ENGINEERING AND RESEARCH DEPARTMENT

REACT 350[®] SYSTEM
CAST-IN-PLACE CONCRETE SLAB
FOR 36" SYSTEMS W/STEEL BACKUP
& AGAINST RIGID BARRIER

SCALE: 1:25

DATE: 9/25/00

DESIGNED BY: D. Kohfeld

APPROVED BY: DEAN ALBERSON

DATE: 09/28/00

PROJECT NO: 114054

SHEET 1 of 2

Revisions	Date	Rev	By	Okd App
ADDED NOTES 6 & 7	07/09/00	B	RSC/DMJ	SPT
ADDED NOTE 8	07/09/00	C	RCC/STI	FJP
WAS EASI P/N: 3535004-0000	1/24/11	-	DPH	/

REACT 350[®] II Cast-in-Place Concrete Slab w/Steel Backup 36"

DWG 114054 Sheet 2 of 2

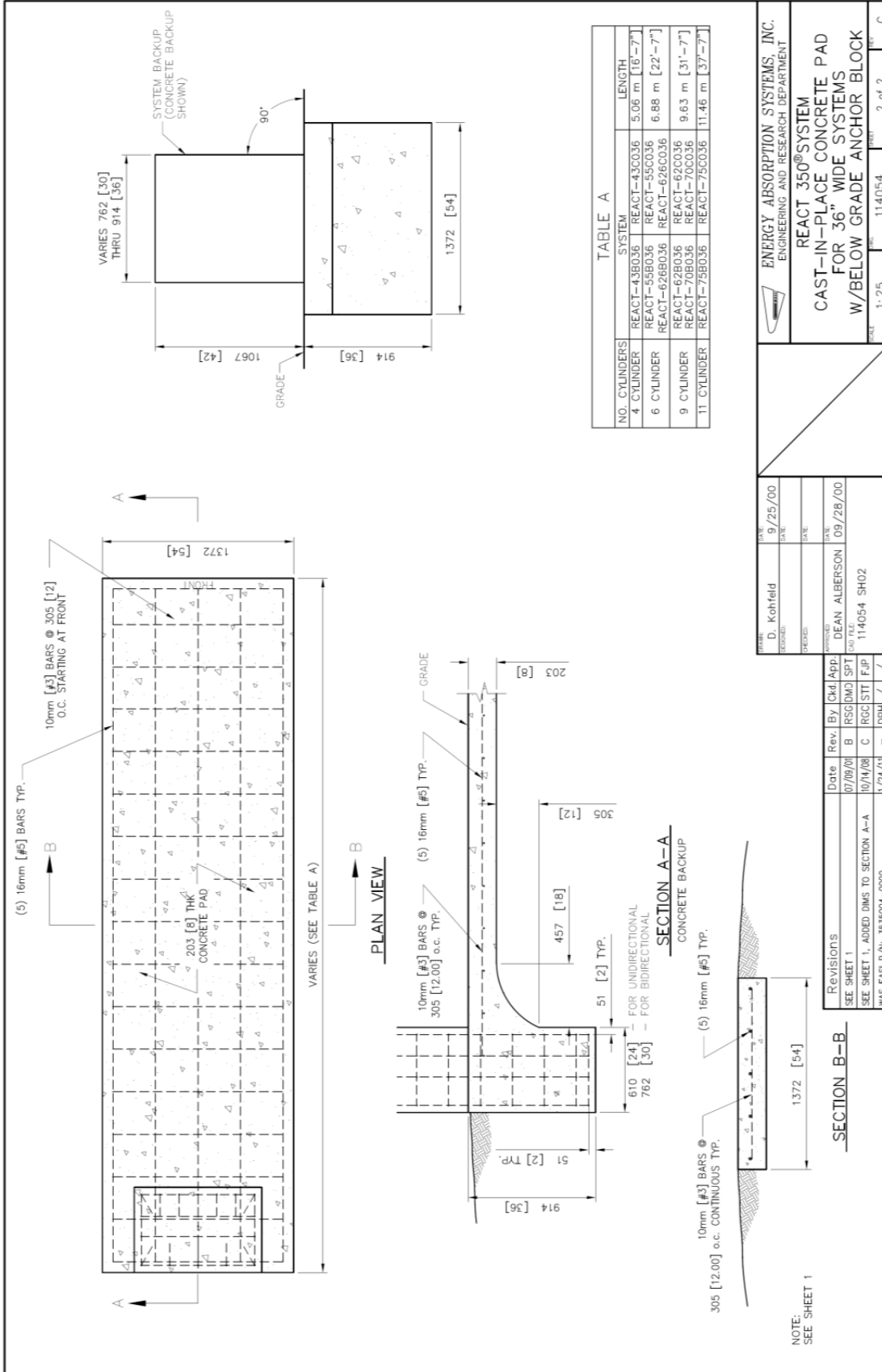

TABLE A

NO. CYLINDERS	SYSTEM	LENGTH	
4 CYLINDER	REACT-43B036	REACT-43C036	5.06 m [16'-7"]
	REACT-55B036	REACT-55C036	6.88 m [22'-7"]
	REACT-62B036	REACT-62C036	9.63 m [31'-7"]
9 CYLINDER	REACT-70B036	REACT-70C036	11.46 m [37'-7"]
	REACT-75B036	REACT-75C036	

ENERGY ABSORPTION SYSTEMS, INC.
ENGINEERING AND RESEARCH DEPARTMENT

REACT 350® SYSTEM
CAST-IN-PLACE CONCRETE PAD
FOR 36" WIDE SYSTEMS
W/BELOW GRADE ANCHOR BLOCK

SCALE: 1:25

DATE: 11/4054

2 of 2

DESIGNED BY	D. Kohfeld	DATE	9/25/00
CHECKED BY		DATE	
APPROVED BY	DEAN ALBERSON	DATE	09/28/00
PROJECT NO.	114054	SHO2	

Date	Rev	By	Okd.App.
10/14/08	C	RCC/STI	FJP
1/24/11	-	DPH	/

SEE SHEET 1, ADDED DIMS TO SECTION A-A
WAS EASI P/N: 3535004-0000

DWG 617967

PARTS LIST		ITEM	STOCK NO.	DESCRIPTION	QTY.
1	SEE TABLE	NOSE COVER, 32X32, TL-3, REACT **			1
2	116888G	SCREW, HW, 1/4X1 1/4, SELF DRILL/TAP P			12
** GORE UNIV (APPLICATION TYPE)					
** TAPE COLOR					

Table		ASSEMBLY NO.	DESCRIPTION	ITEM 1
617967B	NOSE COVER ASSY, GORE, TL-3, REACT Y	617967B	NOSE COVER ASSY, UNIV, TL-3, REACT Y	617965B
618068B	NOSE COVER ASSY, GORE, TL-3, REACT Y	618068B	NOSE COVER ASSY, UNIV, TL-3, REACT Y	617966B
618068B	NOSE COVER ASSY, GORE, TL-3, REACT O	618068B	NOSE COVER ASSY, UNIV, TL-3, REACT O	618066B
618067B	NOSE COVER ASSY, UNIV, TL-3, REACT O	618067B	NOSE COVER ASSY, UNIV, TL-3, REACT O	618067B

UNIVERSAL
ASSEMBLY NO. 617967B
(SEE NOTE 4)

GORE
ASSEMBLY NO. 617967B

UNIVERSAL SHOWN 1

APPLICATION DETAIL

NOTES:

- LOCATE ϕ 1" HOLE IN NOSE COVER OVER ϕ 1" HOLE IN CYLINDER, THEN SECURE WITH SCREWS (ITEM 2).
- SCREW INTO CYLINDER, PUNCHING THRU REFLECTIVE TAPE AND INTO THE CYLINDER. THE END OF THE SHANK OF FASTENER (ITEM 2) IS FLUSH; DO NOT CONTINUE TO SPIN FASTENER.
- NOSE COVER NOT INCLUDED IN MODEL AND MUST BE ORDERED SEPARATELY. DESIRED NOSE MUST BE SPECIFIED WHEN ORDERING. REVIEW APPLICATION DETAIL TO VERIFY WHEN AS SHOWN, APPROACH TRAFFIC PASSES TO LEFT OF SYSTEM AND DEPARTURE TRAFFIC PASSES TO RIGHT OF SYSTEM. FOR APPROACH TRAFFIC ON RIGHT OF SYSTEM NOSE & HAZARD/OBJECT ON THE LEFT OF TRAVELWAY, ROTATE 90°.

Revision	Date	Rev	By	Chk	App
ITEM 2 WAS 116891G (ECP 3380)	4/25/12	A	JMM	JME	A/C

DATE	12/21/2010	BY	D. Hayes Jr
DATE	11/12/2010	BY	A. Cox
DATE	2/22/2011	BY	J. Espinoza
DATE		BY	A. Cox
FILE	617967.kdw		

ASSEMBLY NO. SEE TABLE

ENERGY ABSORPTION SYSTEMS, INC.
ENGINEERING AND RESEARCH DEPARTMENT

REACT 350[®] SYSTEM

NOSE COVER ASSEMBLY, TL-3, REACT

SCALE	NTS	DRAWING	617967	SHEET	1	OF	1	REV	A
-------	-----	---------	--------	-------	---	----	---	-----	---

REACT 350[®] Nose Cover Assembly TL-3

DWG 606182 Sheet 1 of 2

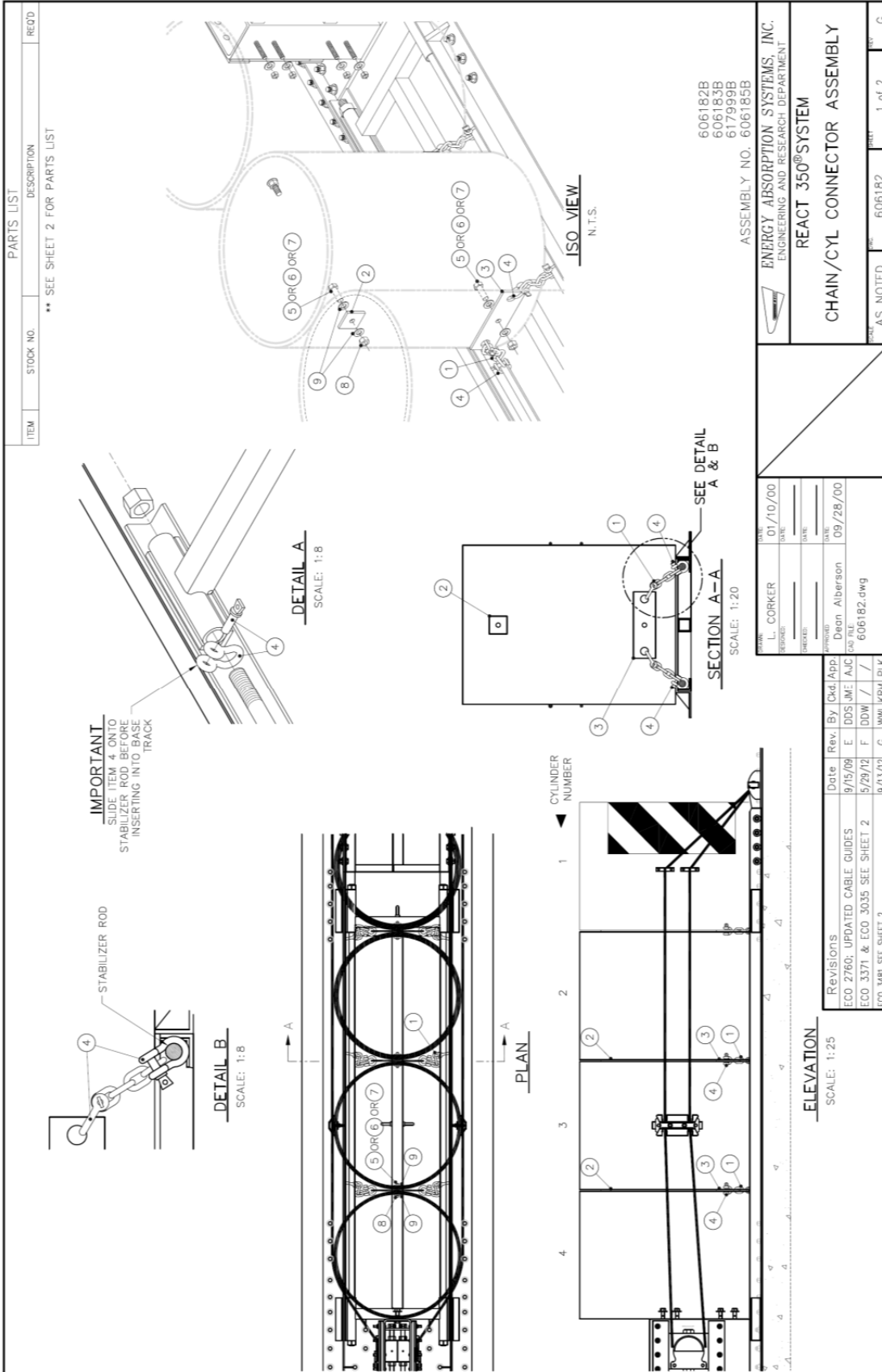

DWG 606182 Sheet 2 of 2

ASSEMBLY NO. 617999B

PARTS LIST (6 CYLINDER REACT 350) TL-3 (62 MPH)

ITEM	STOCK NO.	DESCRIPTION	REQD
1	606177B	CHAIN, PROOF COIL,1/2,4 LINKS,REACT	6.00
2	609236G	FIB ST 1/2X4X4,W/HOLE,G,(REACT)	3.00
3	609256G	FIB ST 1/2X5X15,G,(REACT)	3.00
4	117071G	SHACKLE,ANCHOR,5/8,W/SCREW PIN	12.00
* 5	113564G	BOLT,HX,3/4X4 1/2,G5,G	4.00
* 6	113567G	BOLT,HX,3/4X4,05,G	2.00
* 7	113558G	BOLT,HX,3/4X3 1/2,G5,G	4.00
8	003710G	3/4" HEX NUT A563	10.00
9	118027G	WASHER,FLAT,3/4,HVY,G	20.00

* ITEM 5 USED TO CONNECT CYLINDERS 4 & 5 AND 5 & 6.
 * ITEM 6 USED TO CONNECT CYLINDERS 3 & 4.
 * ITEM 7 USED TO CONNECT CYLINDERS 1 & 2 AND 2 & 3.

ASSEMBLY 606182B

PARTS LIST (4 CYLINDER REACT 350)

ITEM	STOCK NO.	DESCRIPTION	REQD
1	606177B	CHAIN, PROOF COIL,1/2,4 LINKS,REACT	6.00
2	609236G	FIB ST 1/2X4X4,W/HOLE,G,(REACT)	3.00
3	609256G	FIB ST 1/2X5X15,G,(REACT)	3.00
4	117071G	SHACKLE,ANCHOR,5/8,W/SCREW PIN	12.00
* 5	113564G	BOLT,HX,3/4X4 1/2,G5,G	4.00
* 6	113571G	BOLT,HX,3/4X5 1/2,G5,G	2.00
8	003710G	3/4" HEX NUT A563	6.00
9	118027G	WASHER,FLAT,3/4,HVY,G	12.00

* ITEM 5 USED TO CONNECT CYLINDERS 2 & 3 AND 3 & 4.
 * ITEM 6 USED TO CONNECT CYLINDERS 1 & 2.

ASSEMBLY 606183B

PARTS LIST (6 CYLINDER REACT 350)

ITEM	STOCK NO.	DESCRIPTION	REQD
1	606177B	CHAIN, PROOF COIL,1/2,4 LINKS,REACT	6.00
2	609236G	FIB ST 1/2X4X4,W/HOLE,G,(REACT)	3.00
3	609256G	FIB ST 1/2X5X15,G,(REACT)	3.00
4	117071G	SHACKLE,ANCHOR,5/8,W/SCREW PIN	12.00
* 5	113564G	BOLT,HX,3/4X4 1/2,G5,G	4.00
* 6	113571G	BOLT,HX,3/4X5 1/2,G5,G	2.00
7	113558G	BOLT,HX,3/4X3 1/2,G5,G	4.00
8	003710G	3/4" HEX NUT A563	10.00
9	118027G	WASHER,FLAT,3/4,HVY,G	20.00

* ITEM 5 USED TO CONNECT CYLINDERS 3 & 4 AND 4 & 5.
 * ITEM 6 USED TO CONNECT CYLINDERS 5 & 6.
 * ITEM 7 USED TO CONNECT CYLINDERS 1 & 2 AND 2 & 3.

ASSEMBLY 606185B

PARTS LIST (9 CYLINDER REACT 350)

ITEM	STOCK NO.	DESCRIPTION	REQD
1	606177B	CHAIN, PROOF COIL,1/2,4 LINKS,REACT	6.00
2	609236G	FIB ST 1/2X4X4,W/HOLE,G,(REACT)	3.00
3	609256G	FIB ST 1/2X5X15,G,(REACT)	3.00
4	117071G	SHACKLE,ANCHOR,5/8,W/SCREW PIN	12.00
* 5	113564G	BOLT,HX,3/4X4 1/2,G5,G	2.00
* 6	113571G	BOLT,HX,3/4X5 1/2,G5,G	6.00
7	113558G	BOLT,HX,3/4X3 1/2,G5,G	8.00
8	003710G	3/4" HEX NUT A563	16.00
9	118027G	WASHER,FLAT,3/4,HVY,G	24.00

* ITEM 5 USED TO CONNECT CYLINDERS 5 & 6.
 * ITEM 6 USED TO CONNECT CYLINDERS 6 & 7, 7 & 8 AND 8 & 9.
 * ITEM 7 USED TO CONNECT CYLINDERS 1 & 2, 2 & 3, 3 & 4, 4 & 5.

Revisions	Date	Rev	By	Chk	App
ECC 2760; UPDATED CABLE GUIDES	9/15/08	E	DDJ/JME	AJC	
APPLIED DIMS FROM 30308R-0000 REV. F (ECC JARPL, LAB	5/24/12	F	DDW/JME	AJC	
UPDATED ITEM 6 FROM ECO 3033 ADD 6 CVL TL-3	9/13/12	G	WWL/KPM	PLK	
FOR FILE: 30308R-0400, 30308R-0500, & 30308R-1000					

DATE: 01/22/01	DATE: 2/27/01	DATE: 9/28/00
DESIGNED: L. Corker	CHECKED: S. Trojesser	APPROVED: Dean Anderson
DRAWING FILE: 606182.dwg		

ENERGY ABSORPTION SYSTEMS, INC.
ENGINEERING AND RESEARCH DEPARTMENT

REACT 350® SYSTEM

CHAIN/CYL CONNECTOR ASSEMBLY

SCALE: 1:25 PART: 606182 SHEET: 2 of 2

DWG 605780 Sheet 1 of 2

NEXT ASSEMBLY:		MATERIAL:		PARTS LIST		RECD	
TOL. ANGULAR: TOL. LINEAR: UNLESS OTHERWISE NOTED.		SEE TABLE		RESTRAINING CABLES		2.00	
ITEM	STOCK NO.	DESCRIPTION					
1							

CABLE LENGTHS (SELF CONTAINED BACKUPS)		
NO. CYLINDERS	CABLE LENGTH	ITEM #
4	9.12 m [29'-11"]	113924G
6	12.8 m [41'-11"]	113926G
9	18.3 m [59'-11"]	113929G
11	21.9 m [71'-11"]	113931G

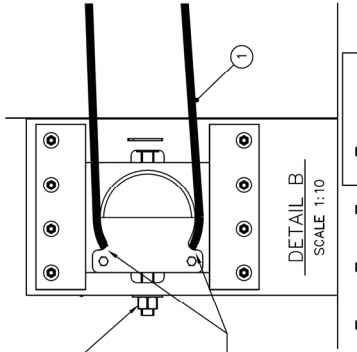

AFTER CABLE IS ASSEMBLED, APPLY TENSION BY TIGHTENING NUT ON CABLE TENSIONER PLATE (EACH SIDE).

REMOVE 2 BOLTS AND NUTS FROM THE TENSIONER PLATE (EACH SIDE) BEFORE CABLE INSTALLATION. THEN REINSTALL AFTER CABLE IS PLACED AROUND TENSIONER.

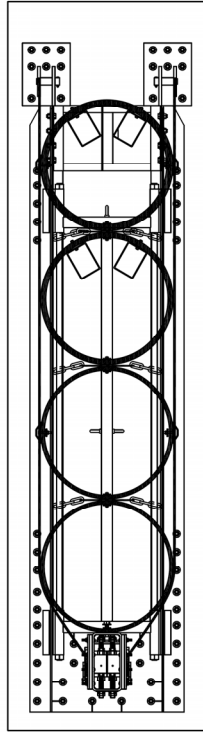

AFTER TENSIONING, CABLE SHOULD NOT DEFLECT MORE THAN 75mm [3"] WITH HEAVY FOOT PRESSURE.

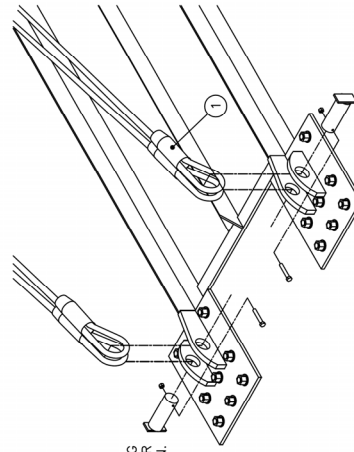
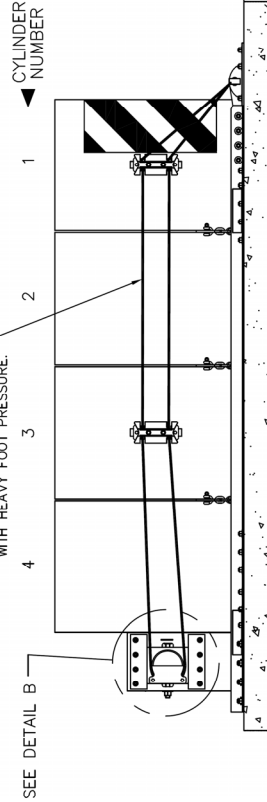

FRONT CABLE ATTACHMENT DETAIL FOR SELF CONTAINED BACKUP

SCALE 1:15

ELEVATION
SCALE 1:30

DATE:	9/25/00	DATE:	
DRAWN:	D. KOHFELD	DATE:	
REVISION:		DATE:	
DESIGNED:	DEAN ALBERSON	DATE:	09/28/00
APPROVED:		DATE:	
PROJECT:	605780	DATE:	
SCALE:	AS NOTED	DATE:	
NO. OF SHEETS:	1 OF 2	DATE:	

ENERGY ABSORPTION SYSTEMS, INC. ENGINEERING AND RESEARCH DEPARTMENT	
REACT 350® SYSTEM	
CABLE ASSEMBLIES	
SCALE:	AS NOTED
NO. OF SHEETS:	1 OF 2
DATE:	

REACT 350® Cable Assemblies

DWG 605780 Sheet 2 of 2

<p>NEXT ASSEMBLY:</p>	<p>TOL. ANGLAR: TOL. LINEAR: UNLESS OTHERWISE NOTED:</p>	<p>PARTS LIST</p> <table border="1" style="width: 100%; border-collapse: collapse;"> <tr> <th>ITEM</th> <th>STOCK NO.</th> <th>DESCRIPTION</th> <th>RECD</th> </tr> <tr> <td>1</td> <td>SEE TABLE</td> <td>RESTRAINING CABLES</td> <td>4.00</td> </tr> <tr> <td>2</td> <td>004004B</td> <td>CBL.3/4,WEDGE,#6</td> <td>4.00</td> </tr> <tr> <td>3</td> <td>004003G</td> <td>CBL.3/4,FERRULE,L6,LIGHT</td> <td>4.00</td> </tr> <tr> <td>4</td> <td>118028G</td> <td>WASHER,FLAT,7/8X3 OD,G</td> <td>4.00</td> </tr> <tr> <td>5</td> <td>118001G</td> <td>WASHER,FLAT,1 1/2X3 OD,G</td> <td>4.00</td> </tr> <tr> <td>6</td> <td>115917G</td> <td>NUT,HX,1 1/2,G</td> <td>4.00</td> </tr> </table>	ITEM	STOCK NO.	DESCRIPTION	RECD	1	SEE TABLE	RESTRAINING CABLES	4.00	2	004004B	CBL.3/4,WEDGE,#6	4.00	3	004003G	CBL.3/4,FERRULE,L6,LIGHT	4.00	4	118028G	WASHER,FLAT,7/8X3 OD,G	4.00	5	118001G	WASHER,FLAT,1 1/2X3 OD,G	4.00	6	115917G	NUT,HX,1 1/2,G	4.00	<p>REVISIONS</p> <table border="1" style="width: 100%; border-collapse: collapse;"> <tr> <th>Date</th> <th>Rev.</th> <th>By</th> <th>Chd.</th> <th>App.</th> </tr> <tr> <td>9/14/09</td> <td>D</td> <td>DDI</td> <td>JME</td> <td>AJC</td> </tr> <tr> <td>1/24/11</td> <td>-</td> <td>DPH</td> <td>/</td> <td>/</td> </tr> <tr> <td>7/9/12</td> <td>E</td> <td>WML</td> <td>JME</td> <td>BRE</td> </tr> </table>	Date	Rev.	By	Chd.	App.	9/14/09	D	DDI	JME	AJC	1/24/11	-	DPH	/	/	7/9/12	E	WML	JME	BRE
ITEM	STOCK NO.	DESCRIPTION	RECD																																																
1	SEE TABLE	RESTRAINING CABLES	4.00																																																
2	004004B	CBL.3/4,WEDGE,#6	4.00																																																
3	004003G	CBL.3/4,FERRULE,L6,LIGHT	4.00																																																
4	118028G	WASHER,FLAT,7/8X3 OD,G	4.00																																																
5	118001G	WASHER,FLAT,1 1/2X3 OD,G	4.00																																																
6	115917G	NUT,HX,1 1/2,G	4.00																																																
Date	Rev.	By	Chd.	App.																																															
9/14/09	D	DDI	JME	AJC																																															
1/24/11	-	DPH	/	/																																															
7/9/12	E	WML	JME	BRE																																															
<p>MATERIAL:</p> <table border="1" style="width: 100%; border-collapse: collapse;"> <thead> <tr> <th colspan="2">CABLE LENGTHS (CONCRETE BACKUPS)</th> </tr> <tr> <th>NO. CYLINDERS</th> <th>ASSEMBLY NO. CABLE LENGTH</th> </tr> </thead> <tbody> <tr> <td>4</td> <td>605780B 12.20 m [40'] 1'39.25G</td> </tr> <tr> <td>6</td> <td>605781B 15.24 m [50'] 1'39.28G</td> </tr> <tr> <td>9</td> <td>605782B 21.34 m [70'] 1'39.30G</td> </tr> <tr> <td>11</td> <td>605799B 27.43 m [90'] 1'39.23G</td> </tr> </tbody> </table>	CABLE LENGTHS (CONCRETE BACKUPS)		NO. CYLINDERS	ASSEMBLY NO. CABLE LENGTH	4	605780B 12.20 m [40'] 1'39.25G	6	605781B 15.24 m [50'] 1'39.28G	9	605782B 21.34 m [70'] 1'39.30G	11	605799B 27.43 m [90'] 1'39.23G	<p>DETAIL A SCALE: 1:15</p>	<p>DETAIL B SCALE: 1:10</p>	<p>FRONT CABLE ATTACHMENT DETAIL FOR CONCRETE BACKUP SCALE: 1:15</p>																																				
CABLE LENGTHS (CONCRETE BACKUPS)																																																			
NO. CYLINDERS	ASSEMBLY NO. CABLE LENGTH																																																		
4	605780B 12.20 m [40'] 1'39.25G																																																		
6	605781B 15.24 m [50'] 1'39.28G																																																		
9	605782B 21.34 m [70'] 1'39.30G																																																		
11	605799B 27.43 m [90'] 1'39.23G																																																		
<p>NOTES:</p> <ol style="list-style-type: none"> 1. SLIDE ITEM 4 ONTO END OF CABLE FIRST, THEN ITEM 3, UN-BRAID CABLE (ITEM 1). INSERT MIDDLE STRAND BETWEEN ITEM 2, PLACE REMAINING 6 STRANDS INTO SLOTS AROUND ITEM 2 THEN PUSH INTO ITEM 3 TO TIGHTEN. 		<p>ASSEMBLY NO. SEE TABLE</p> <p>ENERGY ABSORPTION SYSTEMS, INC. ENGINEERING AND RESEARCH DEPARTMENT</p> <p>REACT 350® SYSTEM CABLE ASSEMBLIES</p>																																																	
<p>ELEVATION SCALE: 1:30</p>		<p>DATE: 02/25/00 DESIGNED: L. Corker CHECKED: _____ APPROVED: _____ DATE: 09/28/00 BY: Dean Alberson DATE FILE: 605780_SHOZ</p>																																																	

DWG 613705

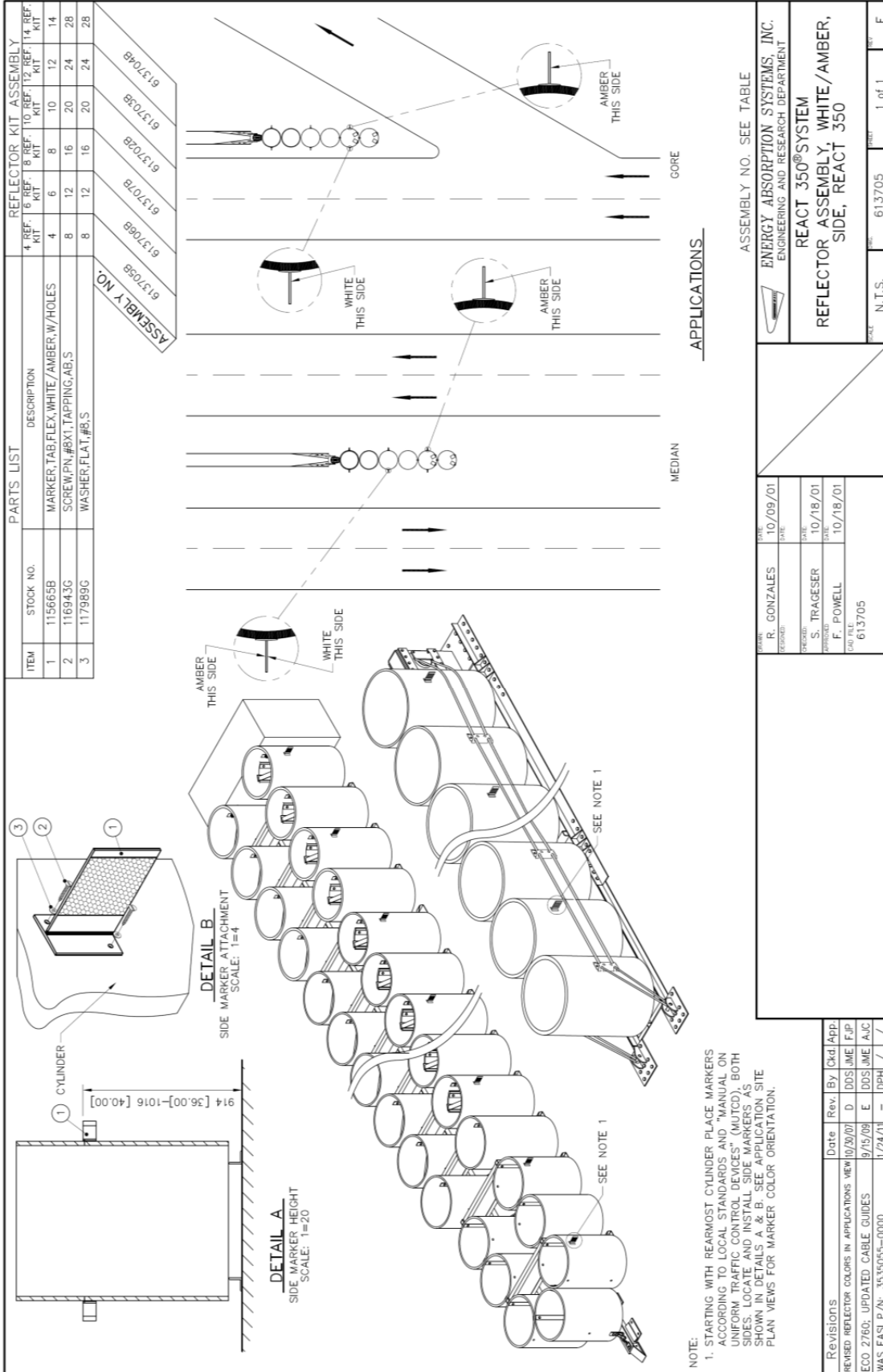

PARTS LIST		REFLECTOR KIT ASSEMBLY							
ITEM	STOCK NO.	DESCRIPTION	4 REF. KIT	6 REF. KIT	8 REF. KIT	10 REF. KIT	12 REF. KIT	14 REF. KIT	
1	115665B	MARKER, TAB,FLEX,WHITE /AMBER,W/HOLES	4	6	8	10	12	14	
2	116943G	SCREW,P/N,#BX1,TAPPING,AB,S	8	12	16	20	24	28	
3	117989G	WASHER,FLAT,#B,S	8	12	16	20	24	28	

ASSEMBLY NO.	613705B
	613705B
	613705B
	613705B
	613705B
	613705B
	613705B
	613705B
	613705B
	613705B

NOTE:
 1. STARTING WITH REARMOST CYLINDER PLACE MARKERS ACCORDING TO LOCAL STANDARDS AND "MANUAL ON UNIFORM TRAFFIC CONTROL DEVICES" (MUTCD), BOTH SIDES. LOCATE AND INSTALL SIDE MARKERS AS SHOWN IN DETAILS A & B. SEE APPLICATION SITE PLAN VIEWS FOR MARKER COLOR ORIENTATION.

Revisions	Date	Rev.	By	Chk	App.
REVISED REFLECTOR COLORS IN APPLICATIONS VIEW	10/29/07	D	DDS	JME	FJP
ECO 2760, UPDATED CABLE GUIDES	9/15/09	E	DDS	JME	AJC
WAS EASI P/N: 3535025-0000	1/24/11	-	DPH	/	/

DATE	10/09/01	DATE	
DESIGNED	R. GONZALES	DATE	
CHECKED	S. TRAGESE	DATE	10/18/01
APPROVED	F. POWELL	DATE	10/18/01
DWG FILE	613705		
SCALE	N.T.S.	REF.	613705
			1 of 1
			E

ASSEMBLY NO. SEE TABLE

ENERGY ABSORPTION SYSTEMS, INC.
 ENGINEERING AND RESEARCH DEPARTMENT

REFLECTOR ASSEMBLY, WHITE /AMBER,
 SIDE, REACT 350

REACT 350® Reflector Assembly, White/Amber, Side

DWG 3535043-0000

KEY ASSEMBLY:		MATERIAL SPECIFICATIONS		TOL ANGULAR: TOL LINEAR:		PARTS LIST			
SEE MATERIAL SPECIFICATIONS		SEE MATERIAL SPECIFICATIONS		UNLESS OTHERWISE NOTED:		ITEM	STOCK NO.	DESCRIPTION	REQ'D
				ASSEMBLY 3535032-0000		1	2765053-0000	STT ST 3X3X1/4X36.W/HOLES	1.00
						2	2700911-0000	STUD.3/4X7 1/2.GS.G	1.00
						3	2704175-0000	NUT.EYE.3/4.G	1.00
						4	2765015-0000	FTB ST 1/2X4X4.W/HOLE.G	1.00
						5	2704341-0000	NUT.HX.3/4.G.GR DH	1.00
						6	2708081-0000	WASHER.FLAT.3/4X2.HVY.G	1.00
						7	2750978-0000	INSTALLATION INSTRUCTIONS.REACT.350	1.00
						8	2735831-3500	MATERIAL SAFETY INFORMATION NOTICE	1.00

ASSEMBLY
3535044-0000
SCALE 1:10

ASSEMBLY
3535045-0000
SCALE 1:10

ASSEMBLY
3535032-0000
SCALE 1:10

DESIGNED BY: L. Corker	DATE: 02/21/01	ASSEMBLY NO. 3535043-0000
CHECKED BY: B. Burgess	DATE: 2/27/01	ENERGY ABSORPTION SYSTEMS, INC. ENGINEERING AND RESEARCH DEPARTMENT
APPROVED BY: D. June	DATE: 2/27/01	REACT 350® SYSTEM
DATE: 2/27/01	DATE: 2/27/01	MISCELLANEOUS HARDWARE
DATE: 2/27/01	DATE: 2/27/01	AS NOTED 3535043-0000

Revisions	Date	Rev.	By	Old App.	Q.C.
ECO 2780; UPDATED CABLE GUIDES	9/15/08	C	DDS	JME	AJC
ITEM 8 WAS 2735831-2500 (ECO 2988)	10/20/10	D	MW	JME	BRE

NOTE:
1. INSTALLER TO DELIVER PULLOUT BRACKET & ASSOCIATED HARDWARE, DRAWINGS & INSTRUCTIONS TO THE USER. USER AGENCY RESPONSIBLE FOR MAINTENANCE.

REACT 350® Misc. Hardware

DWG 606715

ASSEMBLY INSTRUCTIONS:

1. DRILL 2X9/16" HOLES AT THE LOCATION SHOWN. HOLES MUST BE ON A SIDE PERPENDICULAR TO LINE OF HEAD ON IMPACT.
2. ATTACH STANDOFF ASSEMBLY (ITEM 2) WITH SCREWS (ITEM 3), WASHERS (ITEM 6 & 7) AND NUTS (ITEM 8) AS SHOWN. THE STANDOFF MUST BE ORIENTED SO THAT IT IS PERPENDICULAR TO THE SYSTEM.
3. ORIENT DEBRIS COVER SO THAT THE ARROW STENCILED ON THE UNDERSIDE OF THE COVER POINTS TOWARD THE FRONT OF THE SYSTEM.
4. ATTACH DEBRIS COVER TO CYLINDER WITH FLAP SIDE UP USING 8 SCREWS (ITEM 4) AND 8 WASHERS (ITEM 5) AS SHOWN.

TOL ANGLE: ± .1°
TOL DECIMAL: .01
TOL DECIMAL: .005
DO NOT SCALE DRAWING

ITEM	STOCK NO.	DESCRIPTION	QTY.
1	615903B	TOP PRE-ASSEMBLY DEBRIS COVER,36	1
2	614824W	STANDOFF ASSEMBLY,36 REACT PT	1
3	113477G	BOLT,HX,1/2X3,G2,G,ALL,THREAD	2
4	116861G	SCREW,FL,#10X1 1/4,S	B
5	118019B	WASHER,FLAT,1.4X5/8,S	B
6	118009G	WASHER,FLAT,1/2X1 3/8,G	2
7	118082G	WASHER,LOCK,1/2,G	2
8	115939G	NUT,HX,1/2,G	2
9	115397B	INSTRUCTIONS,DEBRIS COVER II ASSY,REACT,36	1

TRAFFIC
SEE ASSEMBLY
NOTE 1

SECTION A-A

Rev	Date	By	Chk	App	ST
1	7/19/2007	JME	S. Thompson	JME	ST
2	8/3/2007	JME	S. Thompson	JME	ST
3	9/3/2007	JME	S. Thompson	JME	ST

UNLESS OTHERWISE NOTED ALL DIMENSIONS ARE IN INCHES
 DIMENSIONS IN PARENTHESES ARE FOR INTERCHANGEABLE PARTS
 DIMENSIONS IN PARENTHESES ARE FOR INTERCHANGEABLE PARTS

ASSEMBLY NO. 606715B 6.40 lbmats
ENERGY ABSORPTION SYSTEMS, INC.
 ENGINEERING AND RESEARCH DEPARTMENT

DEBRIS COVER ASSY II, REACT 350,36
 INSTRUCTION NO. 115397B

606715 1 of 1

REACT 350® 36" Debris Cover Assembly

DWG 618102

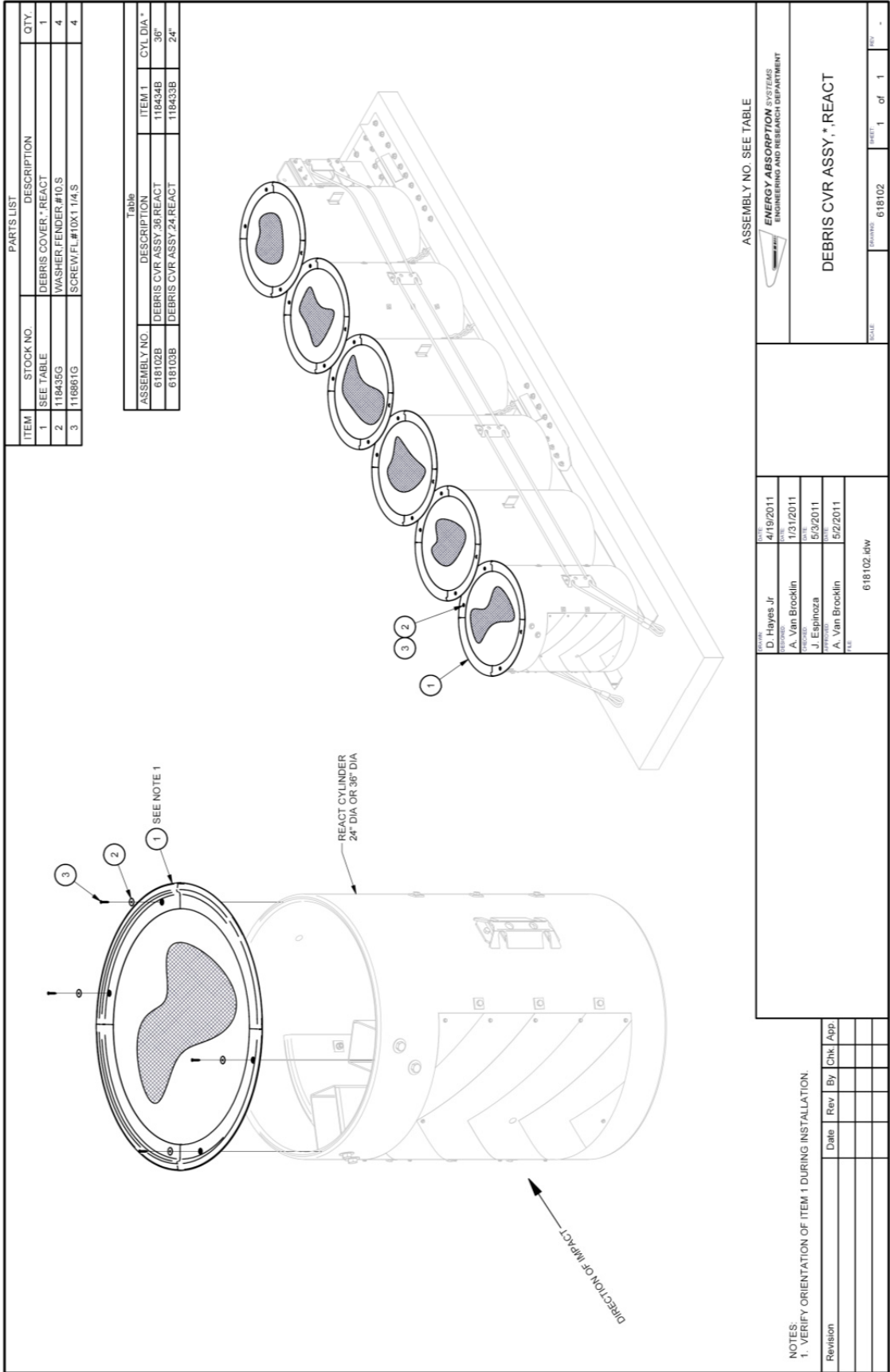

PARTS LIST			
ITEM	STOCK NO.	DESCRIPTION	QTY.
1	SEE TABLE	DEBRIS COVER, .36 REACT	1
2	118435G	WASHER, FENDER #10.S	4
3	118801G	SCREW, FL.#10X1 1/4.S	4

Table			
ASSEMBLY NO.	DESCRIPTION	ITEM 1	CYL DIA *
618102B	DEBRIS CVR ASSY .36 REACT	118434B	36"
618103B	DEBRIS CVR ASSY .24 REACT	118433B	24"

NOTES:
1. VERIFY ORIENTATION OF ITEM 1 DURING INSTALLATION.

Revision	Date	Rev	By	Chk	App

ASSEMBLY NO. SEE TABLE



DEBRIS CVR ASSY, .36 REACT

SCALE	TOLERANCES	SHEET	1	of	1
	618102				

REACT 350® Debris Cover Assembly

DWG 616716

PARTS LIST			
ITEM	STOCK NO.	DESCRIPTION	REQD
1	114426B	DEBRIS COVER,36",REACT 350	1.00
2	116943G	SCREW,P/N,#8X1,TAPPING,AB,S	4.00
3	117994G	WASHER,FLAT,.219 ID X 1.25 OD,G	4.00

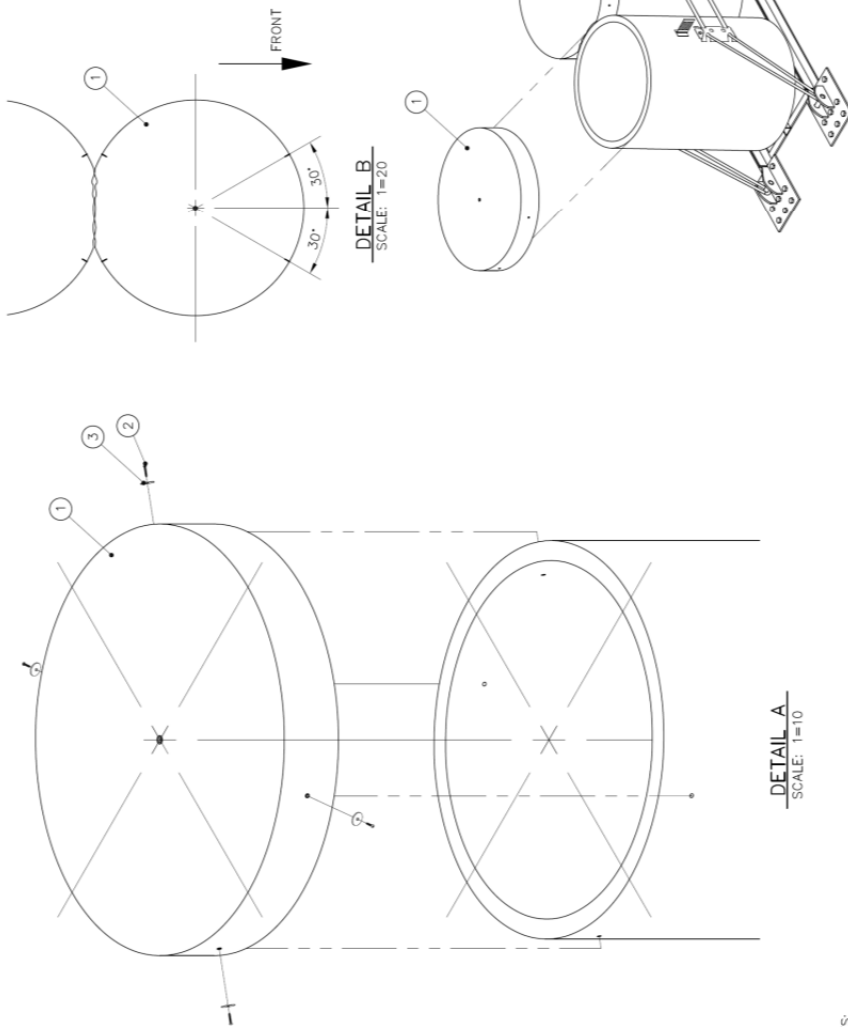

- NOTES:
1. STARTING AT THE FRONT, PLACE COVERS ON EVERY CYLINDER IN SYSTEM. ORIENT FASTENERS IN LINE WITH LENGTH OF SYSTEM AS SHOWN IN DETAIL B.
 2. USE COVER AS A TEMPLATE FOR SCREW LOCATION. KEEP COVERS TIGHT ON SIDE OF SYSTEM.
 3. COVERS WILL BUNCH UP BETWEEN CYLINDERS. FIT COVERS BETWEEN CYLINDERS AS BEST AS POSSIBLE.

Revisions	Date	Rev	By	Chk	App
ECO 2760; UPDATED CABLE GUIDES	9/75/09	A	DDS	JME	AJC
WAS EASI P/N: 3535079-0000	1/31/11	-	DPH	/	/

DATE		DATE	DATE
DESIGNED	R. GONZALES	10/24/01	
DRAWN	JME	11/1/01	
APPROVED	F. POWELL	11/1/01	
DWG FILE	606716		

ASSEMBLY NO. 606716B

ENERGY ABSORPTION SYSTEMS, INC.
ENGINEERING AND RESEARCH DEPARTMENT

REACT 350® SYSTEM

DEBRIS COVER ASSEMBLY,36",REACT 350

SCALE 1=30

1 of 1

REV. A

DWG 3535113-0000

PARTS LIST			
ITEM	STOCK NO.	DESCRIPTION	QTY.
1	2765101-0000	WING PLATE FRONT REACT,DPA	1
2	2765102-0000	WING PLATE MID REACT,DPA	1
3	2765103-0000	WING PLATE REAR REACT,DPA	1
4	2760125-0000	DRIVABLE POST,CG,CZ,DPA	8
5	2760124-0000	POST,CAP,CG,CZ,DPA	8
6	2701012-0000	BOLT,HK,3/4X2 1/2 GR,G	32
7	2700011-0000	BOLT,HK,3/4X2,G5,G	50
8	2708081-0000	WASHER,FLAT,3/4X2,HVY,G	100
9	2704091-0000	NUT,HK,3/4,G	50
10	2750978-1000	INSTALLATION INSTRUCTIONS,DPA,REACT	1

1.84 m (72.38 in)

NOTES:

- CROSS SLOPE OF STRONG SOIL FOUNDATION SHALL NOT EXCEED 8% AND NOT VARY MORE THAN 2% FROM FRONT TO REAR.
- USE THE WING PLATES AS A GUIDE FOR DRIVING POSTS.
- CAUTION, THE REACT SYSTEM MUST BE CORRECTLY ANCHORED FOR PROPER IMPACT PERFORMANCE. DPA ASSEMBLY MAY BE USED TO ATTACH SYSTEM TO STRONG SOIL. ASPHALT OVERLAYS SHOULD BE 102 mm (4.00 in) THICK OR LESS.
- USE ONLY DRIVABLE PILE ANCHOR SYSTEM SUPPLIED BY ENERGY ABSORPTION SYSTEMS INC. REACT SYSTEMS INSTALLED ON SOIL MUST BE INSPECTED TO ENSURE THE ANCHORS ARE STILL PROPERLY SET FOLLOWING EACH IMPACT. RE-ANCHOR AS NECESSARY.
- EVERY SQUARE HOLE IN THE WING PLATES MUST HAVE A DRIVABLE POST ANCHORING IT.
- REFER TO REACT SYSTEM DRIVABLE PILE ANCHOR INSTALLATION APPENDIX FOR FURTHER INFORMATION.

DESIGNED BY	D. Hayes Jr.	DATE	11/22/2006
CHECKED BY	A. Franklin	DATE	9/22/2005
APPROVED BY	A. Franklin	DATE	3/15/2006
PROJECT NO.	R. Broughier	DATE	3/16/2006
DWG NO.		3535113-0000,HW	
DRIVABLE PILE ANCHOR ASSY, REACT			

ASSEMBLY NO. 3535113-0000

ENERGY ABSORPTION SYSTEMS INC.
ENGINEERING AND RESEARCH DEPARTMENT

SCALE: 1:30 DRAWING NO. 3535113-0000 SHEET 1 of 1

REACT 350® Drivable Pile Anchor Assembly

DWG 3535054-0000

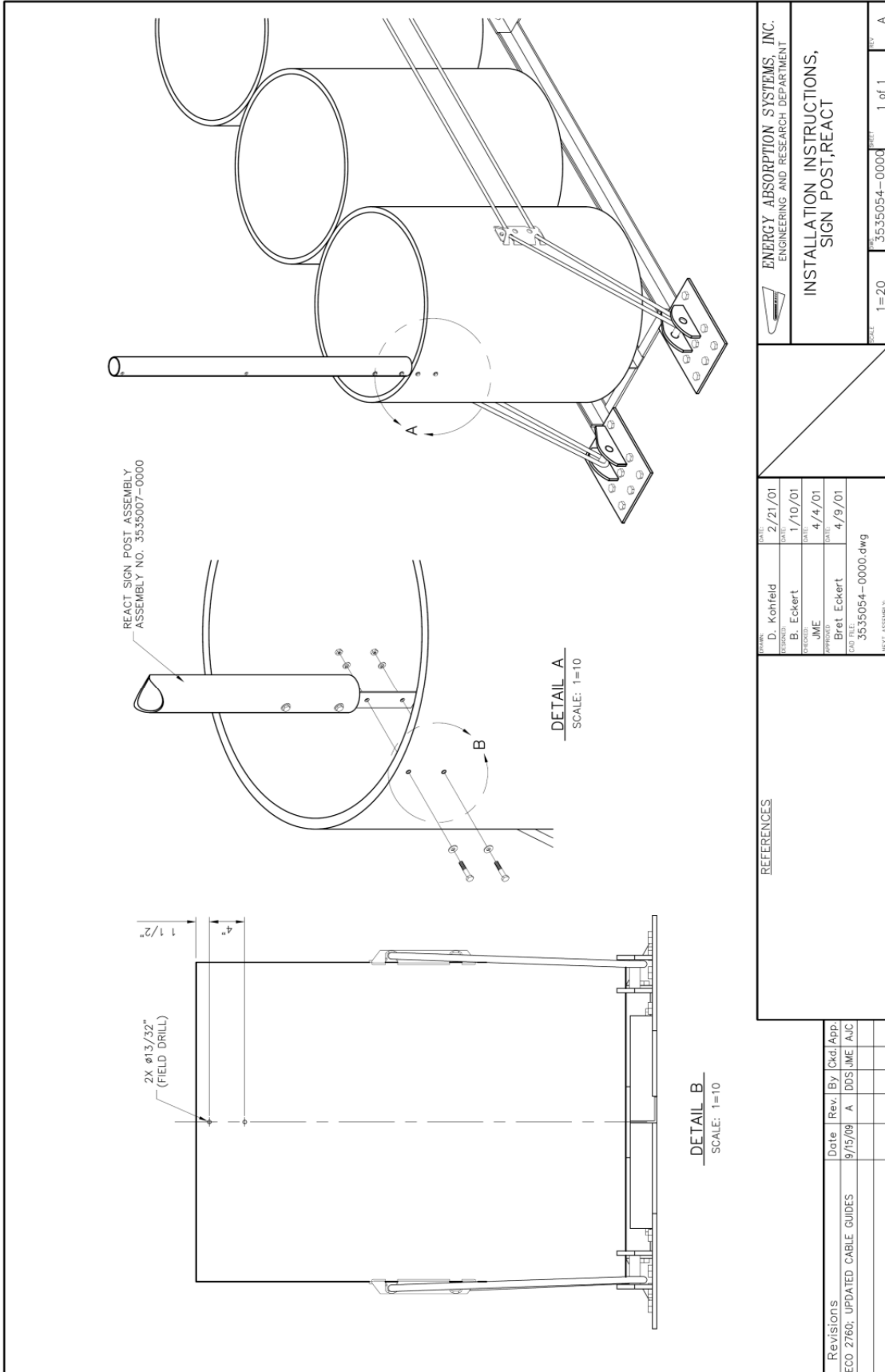

REACT SIGN POST ASSEMBLY
ASSEMBLY NO. 3535007-0000

DETAIL A
SCALE: 1=10

DETAIL B
SCALE: 1=10

<p>ENERGY ABSORPTION SYSTEMS, INC. ENGINEERING AND RESEARCH DEPARTMENT</p>		<p>DATE: 2/21/01 DESIGNED: D. Konfield DATE: 1/10/01 CHECKED: B. Eckert DATE: 4/4/01 APPROVED: JME DATE: 4/9/01 DRAWN: Bret Eckert DATE: 4/9/01 DWG FILE: 3535054-0000.dwg PLOT ASSEMBLY</p>	<p>SCALE: 1=20 PROJECT: 3535054-0000 REV: 1 of 1</p>
<p>INSTALLATION INSTRUCTIONS, SIGN POST, REACT</p>		<p>REFERENCES</p>	
<p>Revisions</p>	<p>Date</p>	<p>Rev. By</p>	<p>Chd. App.</p>
<p>ECO 2760; UPDATED CABLE GUIDES</p>	<p>9/15/09</p>	<p>A</p>	<p>DDS/JME A/JC</p>

REACT 350[®] Sign Post Assembly Instructions

Notes:



2525 Stemmons Freeway

Dallas, Texas 75207

888-323-6374 (USA only)

312-467-6750 (Outside USA)

www.energyabsorption.com

www.highwayguardrail.com